

ADEMCO VISTA SERIES
VISTA-21iP / VISTA-21iPSIA
Security Systems

Installation and Setup Guide

RECOMMENDATIONS FOR PROPER PROTECTION

The Following Recommendations for the Location of Fire and Burglary Detection Devices Help Provide Proper Coverage for the Protected Premises.

Recommendations For Smoke And Heat Detectors

With regard to the number and placement of smoke/heat detectors, we subscribe to the recommendations contained in the National Fire Protection Association's (NFPA) Standard #72 noted below.

Early warning fire detection is best achieved by the installation of fire detection equipment in all rooms and areas of the household as follows: For minimum protection a smoke detector should be installed outside of each separate sleeping area, and on each additional floor of a multi-floor family living unit, including basements. *The installation of smoke detectors in kitchens, attics (finished or unfinished), or in garages is not normally recommended.*

For additional protection the NFPA recommends that you install heat or smoke detectors in the living room, dining room, bedroom(s), kitchen, hallway(s), attic, furnace room, utility and storage rooms, basements and attached garages.

In addition, we recommend the following:

- Install a smoke detector inside every bedroom where a smoker sleeps.
- Install a smoke detector inside every bedroom where someone sleeps with the door partly or completely closed. Smoke could be blocked by the closed door. Also, an alarm in the hallway outside may not wake up the sleeper if the door is closed.
- Install a smoke detector inside bedrooms where electrical appliances (such as portable heaters, air conditioners or humidifiers) are used.
- Install a smoke detector at both ends of a hallway if the hallway is more than 40 feet (12 meters) long.
- Install smoke detectors in any room where an alarm control is located, or in any room where alarm control connections to an AC source or phone lines are made. If detectors are not so located, a fire within the room could prevent the control from reporting a fire or an intrusion.

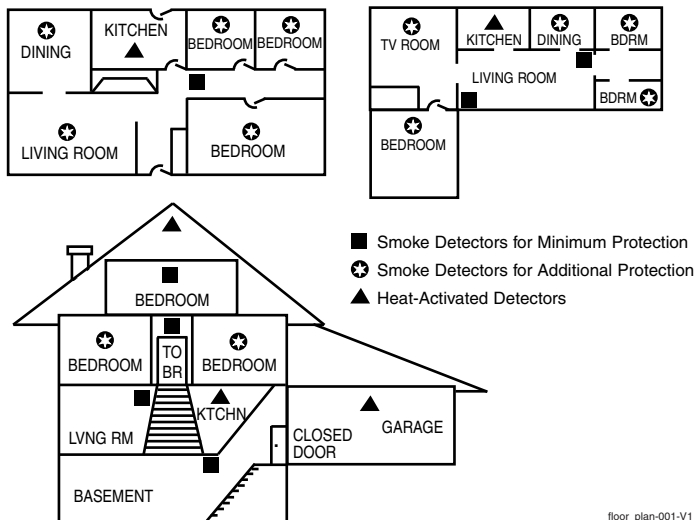

THIS CONTROL COMPLIES WITH NFPA REQUIREMENTS FOR TEMPORAL PULSE SOUNDING OF FIRE NOTIFICATION APPLIANCES.

Recommendations For Proper Intrusion Protection

For proper intrusion coverage, sensors should be located at every possible point of entry to a home or commercial premises. This would include any skylights that may be present, and the upper windows in a multi-level building.

In addition, we recommend that radio backup be used in a security system so that alarm signals can still be sent to the alarm monitoring station in the event that the telephone lines are out of order (alarm signals are normally sent over the phone lines, if connected to an alarm monitoring station).

Table Of Contents

Section 1. Features and Installation Highlights	1-1
Capabilities and Functions.....	1-1
Compatible Devices.....	1-2
Important Installation Highlights (Installer Please Read).....	1-2
Section 2. Mounting and Wiring the Control	2-1
Installing the Control Cabinet and PC Board	2-1
Cabinet and Lock.....	2-1
Mounting the PC Board Alone (no RF Receiver)	2-1
Mounting Board with RF Receiver	2-1
AUXILIARY DEVICE CURRENT DRAW WORKSHEET	2-2
AC Power, Battery, and Ground Connections	2-3
1361 Transformer.....	2-3
1361X10 Transformer	2-3
Battery Connections.....	2-3
Battery Saver Feature	2-3
Earth Ground	2-3
Sounder (Bell) Connections	2-4
Basic Connections.....	2-4
Supervised output	2-4
Connecting the Keypads and Other Addressable Devices	2-4
Connections	2-4
Supplementary Power (optional)	2-4
Keypad Notes.....	2-5
Optional VISTA-GSM4G Module	2-5
Table of Device Addresses	2-5
Hardwire Zones and Zone Expansion	2-6
Hardwire Zones	2-6
Double-Balanced Zones.....	2-6
Zone Doubling.....	2-6
Smoke Detectors.....	2-6
Smoke Detector Notes	2-7
4219/4229 Expansion Zones.....	2-7
Installing the RF Receiver and Wireless Transmitter Zones.....	2-8
Compatible Receivers	2-8
Receiver Connections	2-8
RF Receiver Notes	2-8
Installing a 5800TM Module.....	2-9
Installing the Transmitters	2-9
Transmitter Battery Life	2-9
Installing a Keyswitch	2-10
Keyswitch Connections	2-10
Keyswitch Notes.....	2-10
Connecting Relay Modules, Powerline Carrier Devices and Output Triggers	2-11
4204/4229 Relay Modules	2-11
Powerline Carrier Devices	2-11
On-Board Triggers.....	2-12
Phone Line/Phone Module, Audio Alarm Verification (AAV), and Internet (IP) Connections.....	2-13
Phone Line.....	2-13
4286 Phone Module	2-13
Phone Module Problems.....	2-13
Audio Alarm Verification Connections.....	Error! Bookmark not defined.
Internet (IP) Connection	2-16
VISTA-GSM4G Module Installation	2-16
General Information.....	2-16
Mounting the Module.....	2-16
IP/GSM Status LEDs	2-18
Signal Strength (RSSI).....	2-18
Signal Strength (RSSI) and Status LEDs	2-18
Status Indicator Switch	2-18
Signal Strength and Status LED locations – Status LED Functions Table.....	2-19

Section 3. Programming Overview	3-1
About Programming.....	3-1
Mechanics of Programming	3-1
Data Field Programming Procedures.....	3-1
Interactive Mode Programming (*56, *57, *58, *79, *80, *81, *82).....	3-2
Loading Factory Defaults/Initializing for Download.....	3-2
Exiting the Programming Mode	3-2
Zone Type Definitions	3-2
Section 4. Data Field Programming.....	4-1
About Data Field Programming.....	4-1
System Setup Fields (*20 – *29).....	4-1
Zone Sounds & Timing (*31–*39).....	4-2
Dialer Programming (*40 – *50)	4-2
System Status Report Codes	4-4
Miscellaneous System Fields.....	4-5
Pager Programming Fields.....	4-7
Miscellaneous System Fields.....	4-8
Configurable Zone Type Fields.....	4-9
Touch Screen Keypad (AUI) Enable.....	4-11
Keypad Programming Fields.....	4-11
Section 5. Menu Mode Programming.....	5-1
Zones and Partitions	5-1
About Zone Programming (*56 and *58 Menu Modes)	5-1
*56 Zone Programming Procedure	5-1
Completing Zone Programming.....	5-4
*58 Expert Programming Mode Procedures	5-4
Wireless Key Programming Templates.....	5-6
About Output Device Programming (*79/*80 Menu Mode)	5-9
Programming Output Devices	5-9
*79 Menu Mode: Output Device Mapping.....	5-9
*80 Menu Mode: Defining Output Functions	5-11
About Zone Lists (*81 Menu Mode).....	5-13
Zone List Programming.....	5-14
About Function Keys (*57 Menu Mode).....	5-15
Programming Function Keys.....	5-15
About Descriptor Programming (*82 Menu Mode).....	5-16
Programming Zone Descriptors (Menu Mode *82)	5-16
Adding Custom Words (will not be announced by 4286 Phone Module)	5-17
*29 Menu Mode for IP and GSM Module Programming.....	5-19
IP/GSM Diagnostic Commands (*29 Menu Mode)	5-24
Registering the Control with AlarmNet.....	5-26
Upload/Download via the Internet.....	5-26
Programming Installer and User Schedules.....	5-27
Section 6. System Communication and Operation.....	6-1
Panel Communication with Central Station	6-1
Report Code Formats.....	6-1
Ademco Contact ID®.....	6-3
System Security Codes.....	6-4
Panic Keys	6-6
Setting the Real-Time Clock.....	6-6
Various System Trouble Displays	6-7
Section 7. Testing the System.....	7-1
About Test Procedures.....	7-1
System Test.....	7-1
Checking Transmitter Enrollment (Sniffer Mode)	7-1
Go/No Go Test Mode	7-2
Dialer Communication Test and Periodic Test Reports.....	7-2
Automatic Standby Battery Tests	7-2
Section 8. Specifications & Accessories	8-1
Security Control.....	8-1
Compatible Devices.....	8-1
5800 Series Transmitter Input Loop Identification	8-3
Section 9. Regulatory Agency Statements.....	9-1
Section 10. Limitations and Warranty.....	10-1

Features and Installation Highlights

Compatibility: This document applies to systems with microprocessor version 3.13 or higher.

Features and procedures apply to both the VISTA-21iP and VISTA-21iPSIA, except where differences are noted.

SIA Installations: The VISTA-21iPSIA is a certified SIA-compliant control that meets SIA specifications for False Alarm Reduction. The VISTA-21iP is not certified as SIA-compliant, but can be programmed for False Alarm Reduction. To program for False Alarm Reduction, follow the SIA Guidelines noted in the applicable programming fields.

NOTE: Throughout this manual, device model numbers are Honeywell model numbers unless otherwise noted.

Capabilities and Functions

Feature/Function	Description
Partitions	<ul style="list-style-type: none"> • 2 partitions, can protect two independent areas • Common zone option allows either partition to arm, while leaving a common area (ex. lobby or foyer) disarmed for access into the other partition.
Zones	Up to 48 protection zones plus 16 keyfob zones (zones 49-64) for total of 64 zones: <ul style="list-style-type: none"> • 8 basic hardwired zones (zones 1-8) with optional zone-doubling feature • Up to 40 additional wired zones (zones 9-48) using up to 5 4219/4229 modules • Up to 40 wireless transmitter zones (5800 series; zones 9-48) • Up to 4 configurable zone types
Security Codes	Up to 48 Security Codes, with separate authority levels and partition access
One-button arming	Dedicated keys can arm the system.
Schedules	Up to 32; can control devices and/or auto-arm/disarm
Keypad macros	Up to 4; activated by wired keypads
Paging	Up to 4 pagers; certain system conditions can report to pagers; can use a dedicated key on keypads to send a signal to a pager
Event Logging	100 events; log display is done via Compass Downloader software or installer/master code at Keypad
Zone descriptors	Can assign for all zones (for alpha display keypads and/or 4286 Phone Module).
Bell supervision	Optional, detects external sounder wiring short (when in alarm) or open (when bell is off); causes a trouble condition, keypad display, and sends a report to the central monitoring station, if enabled (field *91, option 1).
RF jam detection	Optional, for wireless systems detects a condition that may impede proper RF reception (i.e., jamming or other RF interference); causes keypad display, and sends a report to the central monitoring station (if trouble reporting is enabled).
Telephone Line Monitoring	Built-in option can monitor the telephone line voltage and can cause a local display, or a display and trouble/alarm sound
Downloading via Phone Line or Internet	<ul style="list-style-type: none"> • Via Standard Phone Line: Using an IBM compatible computer, Compass downloading software, and a compatible HAYES or CIA modem specified by Honeywell. • Via Internet: Supports upload/download programming capability via the Internet using the AlarmNet network and Compass downloading software. This allows site maintenance independent of central station monitoring, and modification to sites globally via the Internet. Also see Internet Reporting below and Internet Connection on the next page.
Internet Reporting	Primary telephone number messages can be reported over the Internet via hardwired high speed Internet connection and/or via an optional on-board VISTA-GSM4G module (using the wireless GSM digital cellular network). The Internet connection and optional module are collectively referred to as the Internal IP/GSM Device.

Compatible Devices

Device	Limits	Notes
Addressable Keypads	8	6150 Fixed-Word Keypad, 6160 Alpha Keypad, 6150V Fixed-Word Display Voice Keypad, 6160V Alpha Display Voice Keypad, 6150RF Keypad/Transceiver
Touch Screen (AUI) Devices	4	Touch Screen (AUI) devices are in addition to the 8 addressable keypads. E.g., 6272, 6280, Tuxedo
4219, 4229 Zone Expander Modules	Up to 5 for up to 40 exp. zones	Zone numbers are predefined according to the device addresses used. See Expander Module Addresses table in Wiring section and set addresses accordingly.
5800 Series Wireless	Up to 40 RF zones	Uses 5881/5883 Series Receivers/Transceivers.
Output relays and/or Powerline Carrier Devices (X-10 type)	Up to 16	Use any combination of 4204, 4229 and or Powerline Carrier Devices. Map output devices via *79 Menu mode.
On-Board Triggers	2	Can be used to reset 4-wire smoke detectors.
Output functions	Up to 48	Program output functions via *80 Menu mode.
4286 Phone Module	Partition 1 only	Provides access to the system via on premises or off-premises phones for arming, disarming, etc., plus control of relay outputs and Powerline Carrier devices.
Audio Alarm Verification	Using AAV module	Honeywell AVS system can be used to permit voice dialog between an operator at the central station and a person at the premises via phone line
Alarm output	12VDC, 2 AMP output	Can drive the compatible sounders; steady output for burglary/panic, or temporal pulse (3 pulses – pause – 3 pulses – pause – 3 pulses. . .) for fire. Uses current limiting circuitry for protection.
Auxiliary Power Output	See note.	12VDC, 600 mA maximum; uses circuit protection.
Backup Battery	See note.	Rechargeable (sealed lead-acid type) 12VDC, 4AH minimum.
Internet Connection and Optional VISTA-GSM4G Module	See note.	Internet connection is made via an on-board Ethernet connector for high speed (broadband) hardwire connections, and/or use of the optional on-board VISTA-GSM4G module.
AC Power Supply	See note.	Plug-in 120VAC transformer, ADEMCO 1361 (1361CN in Canada) or, if using Powerline Carrier devices, ADEMCO 1361X10 Transformer Module

NOTE: All devices and accessories used in a Canadian installation must be Listed for use in Canada.

Important Installation Highlights (Installer Please Read)

- This system uses addressable keypads and Zone Expander Modules (see Table of Addresses in **Section 2. Mounting and Wiring – Connecting the Keypads and Other Addressable Devices**).
- Keypads must be set for addresses 16-23 (first keypad is address 16, which is different from previous controls) and programmed in data fields *190-*196.
- Zone Expander Modules must be set for specific addresses (07-11), based on the zone numbers used.
- 4204 Relay Modules must be set for specific addresses (12-15).
- This control will not power-up unless AC power is connected (will not power-up on battery alone). However, once the system is powered up, it will operate on battery power in the event of AC loss.
- Relays have two programming menu modes: Use *79 Menu mode to map module addresses and device (output) numbers. Use *80 Menu mode to define the output functions.
- This system supports programmable function keys. Use *57 Menu mode to define the function keys.
- This system provides various paging features. Refer to the **Programming Overview** section for a summary on pager programming.

Mounting and Wiring the Control

Installing the Control Cabinet and PC Board

Cabinet and Lock

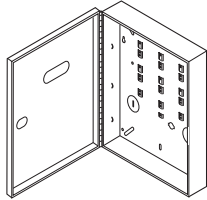

1. Mount the control cabinet to a sturdy wall in a clean, dry area, which is not readily accessible to the general public, using fasteners or anchors (not supplied) with the four cabinet mounting holes.

VISTA-GSM4G Module Note: If using the VISTA-GSM4G module with this control, take signal strength into consideration when choosing a mounting location. Refer to the **VISTA-GSM4G Module Installation** section for details on signal strength.

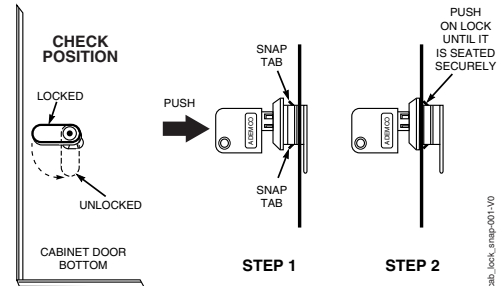

Figure 1. Installing the Cabinet Lock

2. Remove cabinet door, then remove the lock knockout from the door. Insert the key into the lock.
3. Position the lock in the hole, making certain that the latch will make contact with the latch bracket when the door is closed. When correctly positioned, push the lock until the snap tabs hold it securely.

The cabinet can be secured without a lock by using 2 screws in the cover's edge.

Mounting the PC Board Alone (no RF Receiver)

Before installing the cabinet's contents, remove the metal cabinet knockouts required for wiring entry. Do not remove the knockouts after the circuit board has been installed.

1. Hang two short mounting clips (provided) on the raised cabinet tabs (see Detail B).
2. a. Insert the top of the circuit board into the slots at the top of the cabinet. Make sure that the board rests on the correct row (see Detail A).
- b. Swing the base of the board into the mounting clips and secure the board to the cabinet with the accompanying screws (see Detail B).

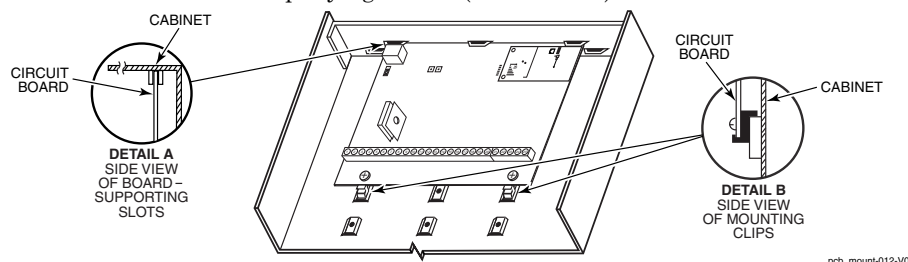

Figure 2. Mounting the PC Board

Optional VISTA-GSM4G Module Note: Refer to the **VISTA-GSM4G Module Installation** section later in this manual for instructions on mounting this optional module.

Mounting Board with RF Receiver

- Do not mount the cabinet on or near metal objects. This will decrease RF range and/or block RF transmissions from wireless transmitters.
 - Do not locate the cabinet in an area of high RF interference (revealed by frequent or prolonged lighting of the LED in the receiver (random flicker is OK))
1. a. Remove the receiver board from its case, then insert the top of the board into the slots at the top of the cabinet, as shown in Detail A in Figure 3 on the next page. Make sure that the board rests on the correct row of tabs.
 - b. Swing the base of the board into the mounting clips and secure it to the cabinet with the accompanying screws.
 - c. Insert the top of the control's board into the slot in the clips and position two clips at the lower edge of the board.
 - d. Swing this board into place and secure it with two additional screws.
 2. Insert grounding lugs (supplied with the receiver) through the top of the cabinet into the left-hand terminals of the antenna blocks (at the upper edge of the receiver board) and secure them to the cabinet top with the screws provided (see Detail B).
 3. Insert the receiver's antennas through the top of the cabinet, into the blocks' right-hand terminals, and tighten the screws.

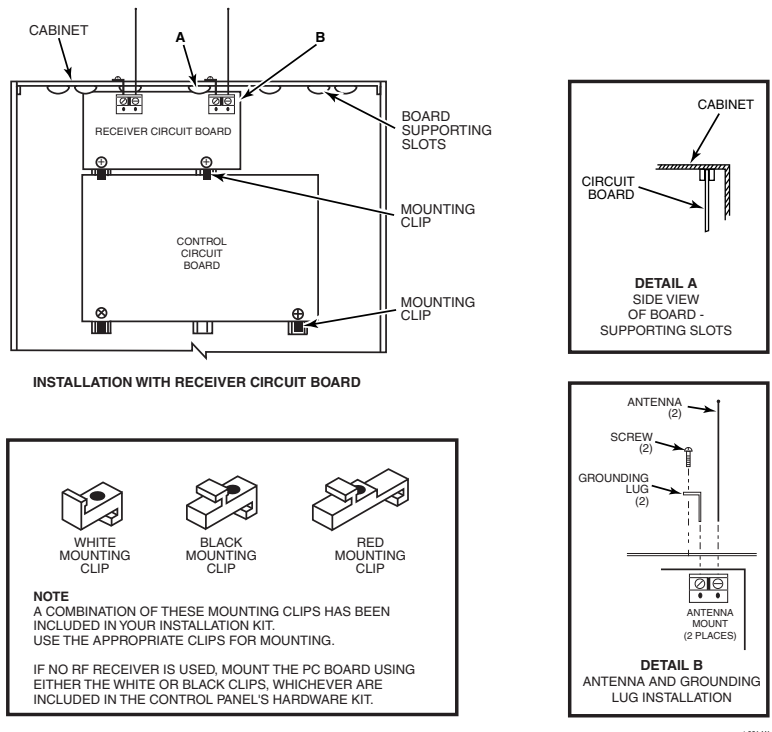

Figure 3. Mounting the PC Board and RF Receiver

AUXILIARY DEVICE CURRENT DRAW WORKSHEET

DEVICE	CURRENT	No. UNITS	TOTAL CURRENT
6150 Fixed-Word Keypad	40mA/70mA**		
6160 Alpha Keypad	40mA/150mA**		
6150V Fixed-Word Display Voice Keypad	60mA/160mA**		
6160V Alpha Display Voice Keypad	60mA/190mA**		
6270 Touch Screen Keypad	180mA/280mA**		
5881/5882 RF Receiver	60mA		
5883 Transceiver	80mA		
4219 Zone Expander	30mA		
4204 Relay Unit	15/180mA‡		
4229 Zone Expander/Relay Unit	30/100mA‡		
4286 Phone Module	300mA		
*			
(Current available from Aux. terminals = 600 mA max.)†		TOTAL =	

*If using hardwire devices such as PIRs, refer to the specifications for that particular unit's current draw.

** Values are for standby/alarm; alarm for keypads means armed with backlighting on and sounder on

†In UL installations, maximum current draw from the Auxiliary Output and the Alarm Output **combined** must not exceed 600 mA (500 mA max from Aux. Output).

‡Values are for relays OFF/relays ON.

CALIFORNIA STATE FIRE MARSHALL (CSFM) AND UL RESIDENTIAL FIRE 24-HOUR BATTERY BACKUP REQUIREMENTS

The California State Fire Marshal and UL have regulations which require that all residential fire alarm control panels must be provided with a backup battery which has sufficient capacity to operate the panel and its attached peripheral devices for 24 hours in the intended standby condition, followed by at least 4 minutes in the intended fire alarm signaling condition. This control panel can meet these requirements without using a supplementary power supply, provided that the panel's auxiliary power and bell output currents are limited as indicated below.

OUTPUT LIMITATIONS AND CORRESPONDING REQUIRED BATTERIES			
OUTPUT CURRENT LIMITATIONS		BATTERY INFORMATION	
Output Current Total	Maximum Auxiliary Current	Battery Capacity To Use (Amp/Hrs)	Recommended Battery (Yuasa Model No.)
600mA maximum total of auxiliary power plus bell output currents	45mA	4AH	NP4-12 (or ADEMCO 467)
	160mA	7AH	NP7-12
	200mA	8AH	NP4-12 (two) ‡
	425mA	14AH	NP7-12 (two) ‡
	500mA	17.2AH	NPG18-12

‡ **NOTE:** Use two batteries, connected in parallel. Obtain Battery Harness Kit 100-02111. (Both batteries will fit inside the cabinet.)

AC Power, Battery, and Ground Connections

1361 Transformer

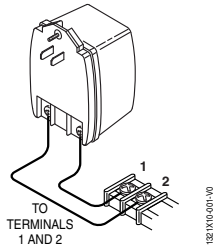

Connect the 1361 Transformer (1361CN in Canada) to terminals 1 and 2 on the control board. See Wire Run Chart for wire size to use.

- Use caution when wiring the transformer to the control to guard against blowing the transformer fuse (the fuse is non-replaceable).

Wire Run Chart

Distance from control	Wire Size
Up to 50 feet	# 20
50–100 feet	# 18
100-250 feet	# 16

- Wiring to the AC transformer must not exceed 250 feet using 16 gauge wire. The voltage reading between terminals 1 and 2 of the control must not fall below 16.5VAC or an “AC LOSS” message will be displayed.
- **Do not plug the transformer into the AC outlet** until all wiring connections to the control are complete. As a safety precaution, always power down the control when making such connections.

1361X10 Transformer (required if using Powerline Carrier devices)

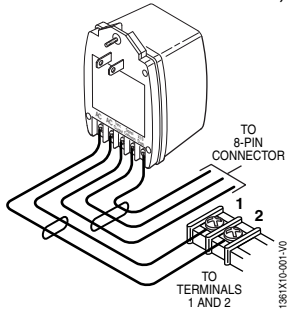

1. Splice one end of a 3-conductor cable to the wire ends of the SA4120XM-1 Cable.
2. Connect the SA4120XM-1 cable plug to the 8-pin connector on the control (see the Summary of Connections diagram for location of the 8-pin connector).
3. Connect the other end of the 3-conductor cable to the 1361X10 Transformer, as shown in Figure 4.

Canadian Installations: See Powerline Carrier Device section for connections to the PSC04 X-10 Interface and trigger pins.

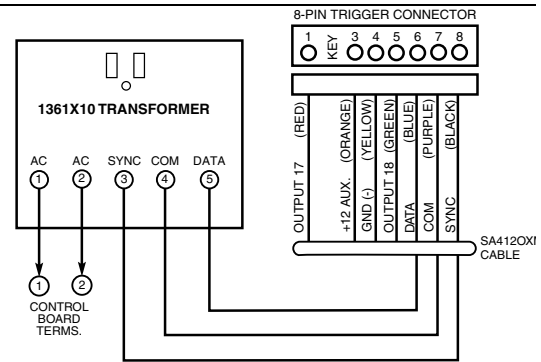
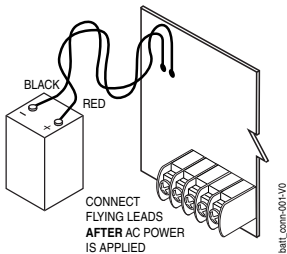

Figure 4. 1361X10 Transformer Connections

Battery Connections



1. Place the 12-volt backup battery in the cabinet.
2. After all connections to the control are completed and AC power has been applied, connect the red and black flying leads on the control board to the battery. Do not attach these leads to the battery terminals until all connections are completed.

UL For UL installations and Residential fire installations, refer to the chart on page 2-2 at left for the correct battery size required to meet the mandatory standby time.

Battery Saver Feature

The battery will disconnect from the system after its voltage decreases below 9VDC. This assists the control panel in recharging the battery when AC is restored.

IMPORTANT: The panel will not power up initially on battery power only. You must plug the transformer in first, and then connect the battery.

Earth Ground

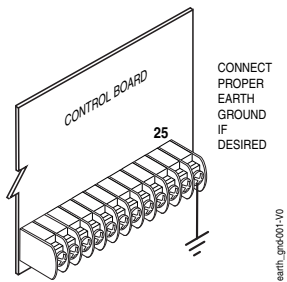

- This product has been designed and laboratory-tested to ensure its resistance to damage from generally expected levels of lightning and electrical discharge, and does not normally require an earth ground.
- If an earth ground is desired for additional protection in areas of severe electrical activity, terminal 25 on the control board, or the cabinet, may be used as the ground connection point. The following are examples of good earth grounds available at most installations.

Metal Cold Water Pipe: Use a non-corrosive metal strap (copper is recommended) firmly secured to the pipe to which the ground lead is electrically connected and secured.

AC Power Outlet Ground: Available from 3-prong, 120VAC power outlets only. To test the integrity of the ground terminal, use a 3-wire circuit tester with neon lamp indicators, such as the UL Listed Ideal Model 61-035, or equivalent, available at most electrical supply stores.

Sounder (Bell) Connections

Basic Connections

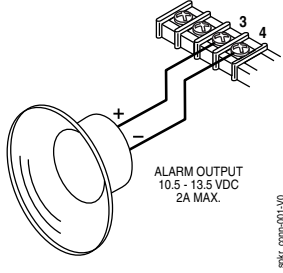

1. Make sounder connections to alarm output terminals 3 (+) and 4 (-).
 2. If not using bell supervision, connect the supplied 820 ohm resistor across terminals 3 and 4. If using bell supervision, see Supervised Output paragraph below.
- The 12VDC sounder output activates when an alarm occurs.
 - Total current drawn from this output cannot exceed 2 amps (going beyond 2 amps will overload the power supply, or may cause the electronic circuit protecting the sounder output to trip).
 - You must install a battery, since the battery supplies this current.

Supervised Output

1. Connect the supplied 820 ohm Bell Supervision EOL resistor across the terminals of the last sounder. See Figure 5.

Bell Supervision Note: The value of the Bell Supervision EOL Resistor is 820 ohms.

High Impedance Device Note: If a high impedance sounding device is used (ex. 745X3), the bell supervision resistor (included) must be installed at the device.

2. Set field *91 Option Selection for Bell Supervision (option 1).

This control complies with NFPA requirements for temporal pulse sounding of fire notification appliances. Temporal pulse sounding for a fire alarm consists of: 3 pulses – pause – 3 pulses – pause – 3 pulses–etc..

UL

- Use only UL Listed sounding devices for UL installations.
- Bell supervision is required for fire alarm installations.
- The total current drawn from the alarm output and the auxiliary power output, combined, cannot exceed 600 mA. In addition, the sounding device must be a UL Listed audible signal appliance rated to operate in a 10.2-13.8 VDC voltage range, and must be mounted indoors.

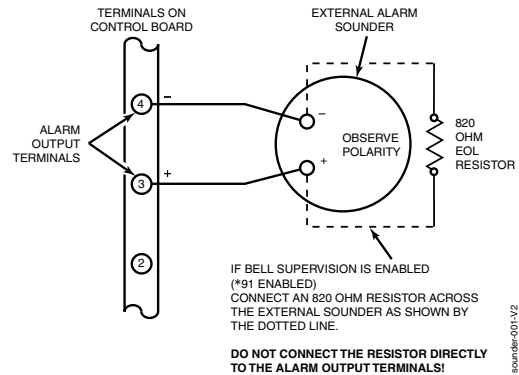
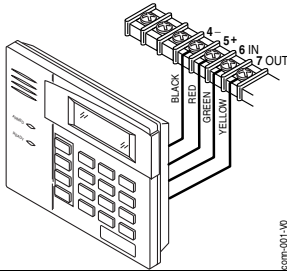

Figure 5. Sounder Wiring (Supervised)

Connecting the Keypads and Other Addressable Devices

Connections



Connect keypads and other addressable devices (4204, 4219, 4229, 4286, 5881, etc.) to the control's keypad terminals as shown on the Summary of Connections diagram. The system supports up to 8 keypads, which can be assigned to partitions in any combination (see program fields *190-*196).

Use the Table of Device Addresses to determine the appropriate address for each device.

Determine wire size using the Wire Run Chart on the following page. For single 4-wire runs, determine the current drawn by all units, then refer to the Wiring Run chart to determine the maximum length that can be safely used for each wire size.

Supplementary Power (optional)

UL Use a UL Listed, battery-backed supply for UL installations. The battery supplies power to these keypads in case of AC power loss. The battery-backed power supply should have enough power to supply the keypads with the UL required minimum standby power time.

Use supplementary power if the control's aux. power load for all devices exceeds 600mA (suggested power supply: AD12612). Connect as shown in Figure 6. Be sure to connect the negative (-) terminal on the power supply unit to terminal 4 (AUX -) on the control.

IMPORTANT: Keypads powered from supplies that do not have a backup battery will not function if AC power is lost. Make sure to power at least one keypad in each partition from the control's auxiliary power output.

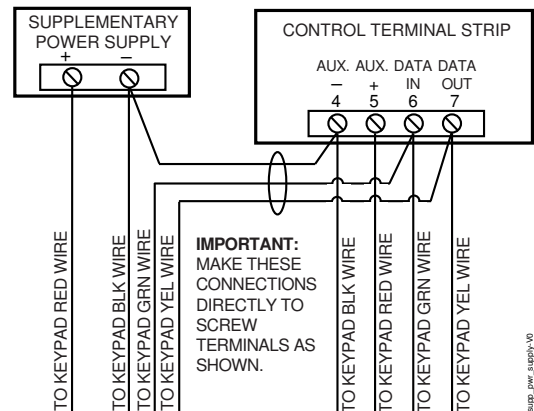

Figure 6. Using a Supplementary Power Supply

Keypad Notes

Set device addresses. Refer to the instructions included with the devices and set each address according to the **Table of Device Addresses**.

See **Keypad Programming Fields** (fields *190-*196) in **Section 4. Data Field Programming** for details on enabling keypad addresses, assigning keypad partitions and selecting keypad sounding options.

IMPORTANT: Each keypad must be assigned a unique, predefined address, **from 16 to 23. The first keypad is address 16** (default = partition 1, all sounds enabled).

TOUCH SCREEN KEYPAD (AUI) NOTES:

- Use of up to four AUI devices (e.g., 6272, Symphony, 6280, Tuxedo) is independent from standard keypads and does not affect the number of standard keypads the system can support.
- AUI devices must be set for address 1 or 2, or address 5 or 6 depending on which unit is enabled in field *189.
- To ensure proper AUI device operation, use AUI devices with the following rev levels: 6270 series use version 1.0.9 or higher; 8132/8142 (Symphony) series use version 1.1.175 or higher.

Optional VISTA-GSM4G Module

Refer to the **VISTA-GSM4G Module Installation** section later in this manual for detailed explanation of its installation.

The module's address is internally set to 03 and cannot be changed.

Wire Run Chart For Devices* Drawing Aux Power From The Control (12V+ & 12V-)					
Wire Size	TOTAL CURRENT DRAWN BY ALL DEVICES CONNECTED TO A SINGLE WIRE RUN				
	50 mA or less	100 mA	300 mA	500 mA	600 mA
#22	900 ft (274m)	450 ft (137m)	150 ft (46m)	90 ft (27m)	75 ft (23m)
#20	1400 ft (427m)	700 ft (213m)	240 ft (73m)	140 ft (43m)	120 ft (37m)
#18	1500 ft (457m)	1100 ft (335m)	350 ft (107m)	220 ft (67m)	170 ft (52m)
#16	1500 ft (457m)	1500 ft (457m)	550 ft (168m)	350 ft (107m)	270 ft (82m)

* Includes Keypads, RF Receivers, Zone Expander/Relay Units, and 4286 Phone Module.

Maximum wire lengths for any device that is homerun to the control can also be determined from the Wiring Run Chart, based on the current draw of that device alone.

The length of all wire runs for both partitions combined must not exceed 1500 feet (457m) when unshielded quad conductor cable is used (750 feet if shielded cable is used). This restriction is due to the capacitive effect on the data lines when quad cable is used.

Table of Device Addresses

This Device	Uses Address	Reports as††	Enabled By...
RF Receiver	00	100	*56 zone programming: input device type entry
AUI 1	01		automatic if AUI enable field *189 enabled for AUI 1
AUI 2	02		automatic if AUI enable field *189 enabled for AUI 2
AUI 3	05		automatic if AUI enable field *189 enabled for AUI 1
AUI 4	06		automatic if AUI enable field *189 enabled for AUI 2
Internal IP/GSM Device	03	103	automatic if enabled in menu mode *29
4286 Voice Module	04	104	automatic if phone module access code field *28 enabled
Zone Expanders (4219/4229):			*56 zone programming: input device type, entry 2, then:
module 1 (for zones 09 - 16)	07**	107	automatic if zone no. 9-16 set as AW type or relay assigned
module 2 (for zones 17 - 24)	08	108	automatic if zone no. 17-24 set as AW type or relay assigned
module 3 (for zones 25 - 32)	09	109	automatic if zone no. 25-32 set as AW type or relay assigned
module 4 (for zones 33 - 40)	10	110	automatic if zone no. 33-40 set as AW type or relay assigned
module 5 (for zones 41 - 48)	11	111	automatic if zone no. 41-48 set as AW type or relay assigned
Relay Modules (4204):			*79 output device programming: device address prompt:
module 1	12	112	entered at device address prompt
module 2	13	113	entered at device address prompt
module 3	14	114	entered at device address prompt
module 4	15	115	entered at device address prompt
Keypads:			data field programming as listed below:
keypad 1	16	n/a	always enabled for partition 1, all sounds enabled.
keypad 2	17	n/a	data field *190
keypad 3	18	n/a	data field *191
keypad 4	19	n/a	data field *192
keypad 5	20	n/a	data field *193
keypad 6	21	n/a	data field *194
keypad 7	22	n/a	data field *195
keypad 8	23	n/a	data field *196
RIS Communication	25	n/a	automatic (used for Remote Interactive Services)
5800TM Module	28	n/a	automatic

** address 07 not available if zone-doubling enabled

†† Addressable devices are identified by "1" plus the device address when reporting. Enter a report code for zone 91 to enable addressable device reporting (default = reports enabled). See field *199 for addressable device (ECP) 3-digit/2-digit identification keypad display options.

Hardwire Zones and Zone Expansion

Hardwire Zones

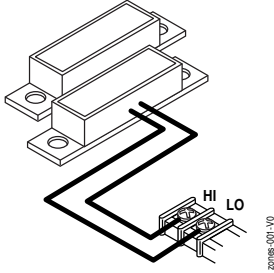

Normally Open Zones/ N.O. EOLR Zones

1. Connect open circuit devices in parallel across the loop; for EOLR zones, connect the EOLR across the loop wires at the last device.
2. Enable normally open/EOLR zones using Zone Programming mode, “Hardwire Type” prompt.

Normally Closed Zones/ N.C. EOLR Zones

1. Connect closed circuit devices in series in the high (+) side of the loop; for EOLR zones, connect the EOLR in series following the last device.
2. Enable normally closed/EOLR zones using Zone Programming mode, “Hardwire Type” prompt.

End of Line Resistor (EOLR) Notes

- If the EOLR is not at the end of the loop, the zone is not properly supervised and the system may not respond to an “open” on the zone.
- Zone 1 is intended for EOLR only.

UL For UL commercial burglar alarm installations, use EOLR zones.

Double-Balanced Zones

Connect as shown below (resistor provided for one device).

IMPORTANT: Double-balanced zones provide zone tamper protection, and should be used as burglary zones only.

Do not use double-balanced zones as fire zones.

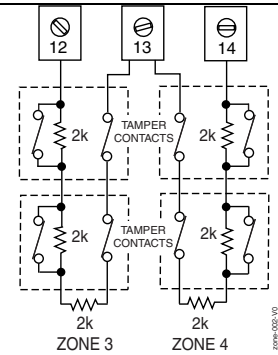

Fig. 7. Typical Double Balanced Zones

Zone Doubling

This feature provides two hardwired normally closed zones for each standard hardwired zone connected to the control’s terminals (but does not increase the total number of zones supported by the control). If enabled (Zone Programming mode, “Hardwire Type” prompt, option “3”), hardwire zones are automatically paired as shown in the table. Connect as shown (resistors provided).

- **Do not use zone doubling for fire zones.**

NOTE: A short across the EOL (i.e., at terminal) on either zone of a zone-doubled pair or on a double-balanced zone causes a tamper condition (displayed as CHECK plus zone numbers).

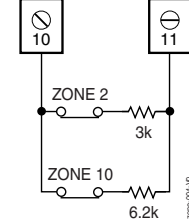
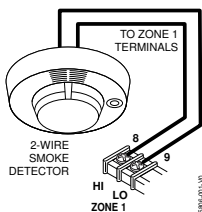

Fig. 8. Typical Zone Doubling Wiring

Zone Doubling Table	
Zone	Paired with zone
2	10
3	11
4	12
5	13
6	14
7	15
8	16

NOTE: Zone numbers used for zone doubling cannot be used for anything else (ex. cannot be used for 4219 zones)

Smoke Detectors



1. Connect up to 16 (10, if “clean me” option used) 2-wire smoke detectors across zone 1 terminals 8 (+) and 9 (-) as shown in the Summary of Connections diagram at the back this manual. Observe proper polarity when connecting the detectors.
2. Connect an EOL resistor across the loop wires at the last detector.
3. Connect 4-wire smoke detectors (up to trigger output 17’s maximum current draw 100mA) to any zone from 2-8 as shown in Figure 9a and 9b (on next page).

Power Reset: This control does not automatically reset power to 4-wire smoke detector zones, so you must use a relay (e.g., 4204, 4229), or on-board trigger to reset power (also required for fire verification). Do this by programming the designated relay/trigger as zone type 54 (fire zone reset); see **On-Board Trigger** section for other information.

NOTE: Maximum current on trigger 17 is 100mA.

Smoke Detector Notes

- **Fire Verification (zone type 16):** The control panel will “verify” a fire alarm by resetting the smoke detectors after the first alarm trigger, and then waiting up to 90 seconds for a second alarm trigger. If the smoke detector or thermostat does not trigger again, the control will disregard the first trigger, and no alarm signal will occur. This feature eliminates false alarms due to electrical or physical transients.
SIA Installations: If using fire verification on zones other than zone 1, UL Fire Alarm Listed relay accessories must be used to reset power as described in the Power Reset paragraph above.
- The zone 1 alarm current supports only one smoke detector in the alarmed state.
- **Clean Me Option:** If enabled (field *174 = 1; *56 zone programming, response time prompt = 3), certain ESL smoke detectors send “clean me” reports as appropriate. If used, the maximum number of detectors is reduced to 10 (not standard 16). Refer to the ESL documentation included with the smoke detector for information regarding compatibility with the clean-me option.
- Do not use 4-wire smoke detectors on zone 1.

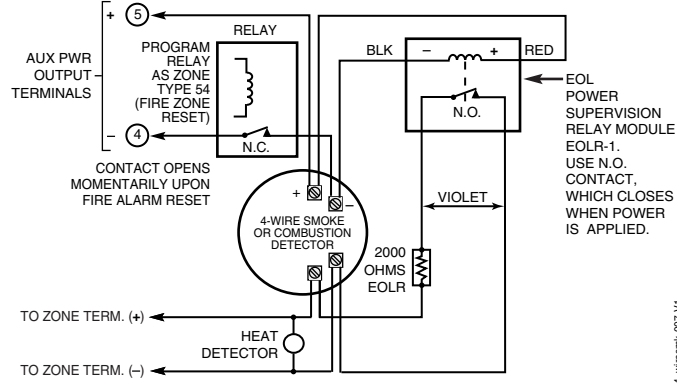

Figure 9a. 4-Wire Smoke Detector Using Relay for Power Reset

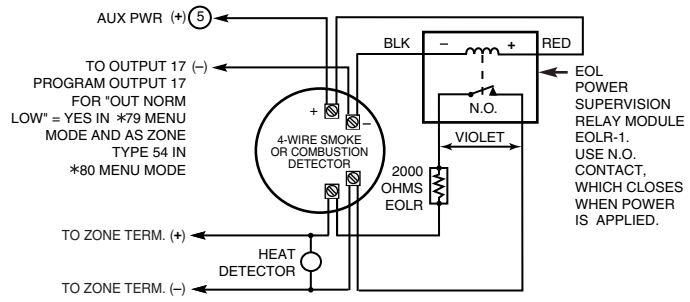
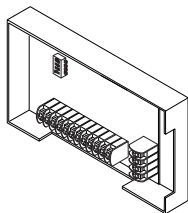

Figure 9b. 4-Wire Smoke Detector Using Output 17 for Power Reset

4219/4229 Expansion Zones



1. Connect each module to the control’s keypad terminals and set the device addresses. See the Table of Device Addresses to select an appropriate address for each module.
 - Supports up to 40 expansion zones using up to 5 Zone Exp. Modules.
2. Connect sensors to the module’s loops.
 - Use end-of-line resistors at the end of loops connected to the 4219/4229 modules.
 - Expansion zones have normal response time (300–500 msec), except zone connected to each module’s loop “A,” which can be set for fast response (10–15 msec).
3. If using relays with the 4229, connect the desired field wiring to the unit's relay contact terminals.

Installing the RF Receiver and Wireless Transmitter Zones

Compatible Receivers

Use any ADEMCO 5800 Series Wireless Receivers, such as:

RF Receiver	No. of Zones
5881L/5882L	up to 8
5881M/5882M	up to 16
6150RF	
5881H/5882H, 5883, 6160RF	up to 40 plus 16 buttons

Receiver Connections

1. Set Device Address to "00" (set all switches to the right, "off" position).
2. Mount the receiver, noting that the RF receiver can detect signals from transmitters within a nominal range of 200 feet.
3. Connect the receiver's wire harness to the control's keypad terminals. Plug the connector at the other end of the harness into the receiver. Refer to the installation instructions provided with the receiver for further installation procedures regarding antenna mounting, etc.

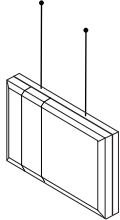

WIRELESS ZONE NUMBERS

transmitter zones 9-48
button zones 49-64

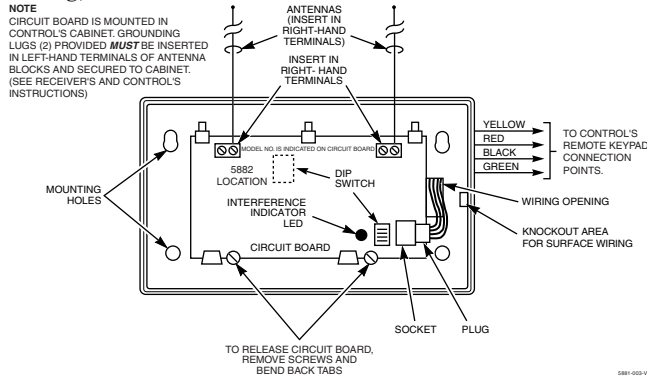

Figure 10. 5881/5882 RF Receiver (cover removed)

RF Receiver Notes

† These fields must be enabled for Residential Fire, UL Residential Burglar Alarm, and UL Commercial Burglar Alarm installations.

Set the following options:

- *22 RF Jam Option†
 - *24 RF House ID Code (if using wireless keypads) for each partition
 - *67 Transmitter Low Battery Report Code†
 - *75 Transmitter Low battery restore report code†
- The receiver is supervised and a trouble report is sent ("CHECK 100" displayed) if communication between the panel and receiver is interrupted, or if no valid RF signals from at least one supervised transmitter are received within 12 hours.
- If the receiver is mounted remotely:
- Place the RF receiver in a high, centrally located area for best reception.
 - Do not locate the receiver or transmitters on or near metal objects. This will decrease range and/or block transmissions.
 - Do not locate the RF receiver in an area of high RF interference (indicated by frequent or prolonged lighting of the LED in the receiver; random flicker is OK).
 - Do not locate RF receiver closer than 10 feet from any keypads to avoid interference from the microprocessors in those units.

Installing a 5800TM Module

- Use this module only if you are using one or more wireless bi-directional keypads or keyfobs with a wireless Receiver; 5800TM is not necessary if using a Transceiver (e.g., 5883).
 - The 5800TM must be set to address 28 (cut red-W1 jumper).
 - The 5800TM can be used in partition 1 only.
 - For additional information regarding the 5800TM, refer to the 5800TM's instructions.
1. Mount the 5800TM next to the RF receiver (between one and two feet from the receiver's antennas) using its accompanying mounting bracket. Do not install within the control cabinet.
 2. Connect the 5800TM to the control panel's keypad connection terminals as shown on the Summary of Connections diagram and set to address 28.

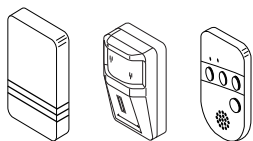
Installing the Transmitters

- Refer to the table of compatible devices at the back of this manual.
- Supervised transmitters† send check-in signals to the receiver at 70-90 minute intervals. If at least one check-in message is not received from each transmitter within a 12-hour period, the “missing” transmitter number(s) and “CHECK” is displayed. († Hand-held transmitters, e.g., 5802, 5802CP, 5804, 5804BD, 5827, 5827BD, do not send check-in signals.)
- To be sure reception of the transmitter's signal at the proposed mounting location is adequate, perform a Go/No Go Test, described in the **Testing the System** section.
- Install transmitters in accordance with the instructions provided with each.
- Set 5827, 5827BD, 5804BD wireless keypads to the programmed House ID (field *24), using its DIP switches (5827) or follow the instructions provided with the device.
- Use *56 or *58 Zone Programming Menu modes to program zone information and enroll transmitters (zones 9-48, buttons 49-64).
- **Wireless Keys:** Use Wireless Key Programming Templates section of the *58 Zone Programming Menu mode to program zone information and enroll each button of the wireless keys used. Once a wireless key is enrolled, it must be assigned to a user before it becomes active. See Adding/Deleting Security Codes section for procedure.

ULC NOTE: In accordance with ULC standards, the RF supervision period for the VISTA-21iPCN is three hours for Fire zones (Zone Type 9 and 16) and 12 hours for all other zone types.

UL The following transmitters are not intended for use in UL installations: 5802MN, 5802MN2, 5804, 5804BD, 5814, 5816TEMP, 5819, 5819WHS & BRS, and 5850.

The 5827BD and 5800TM can be used in UL Listed Residential Burglar installations.

Transmitter Battery Life

- See Wireless Transmitter paragraph in the **Limitations of This Alarm System** statement located at the end of this manual for information on transmitter battery life.
- Some transmitters (e.g., 5802 and 5802CP) contain long-life but non-replaceable batteries, and no battery installation is required. At the end of their life, the complete unit must be replaced (and a new serial number enrolled by the control).
- Button-type transmitters (such as 5801, 5802, and 5802CP) should be periodically tested for battery life.
- The 5802MN and 5804 Button Transmitters have replaceable batteries.

Do not install batteries in wireless transmitters until you are ready to enroll during system programming. After enrolling, batteries need not be removed.

Installing a Keypad

Keypad Connections

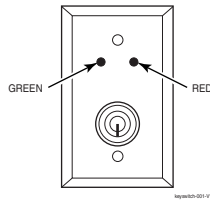

1. Connect the 4146 keyswitch's normally open momentary switch to a zone's (2-8) terminals. Remove the 2000 ohm EOL resistor if connected across the selected zone.
2. Using a standard keypad cable as shown:
Connect the yellow and white keyswitch wires to trigger connector pin 3 (+12V). Connect the Red and Green LED wires to the appropriate output 17/output 18 trigger connector pins.
3. Connect a 2000 ohm EOL resistor across the momentary switch.
4. You can wire an optional closed-circuit tamper switch (model 112) in series with the zone. If the switchplate is then removed from the wall, the tamper will open, disabling keyswitch operation until the system is next disarmed from the keypad. If the tamper is opened when the system is armed, an alarm will occur.

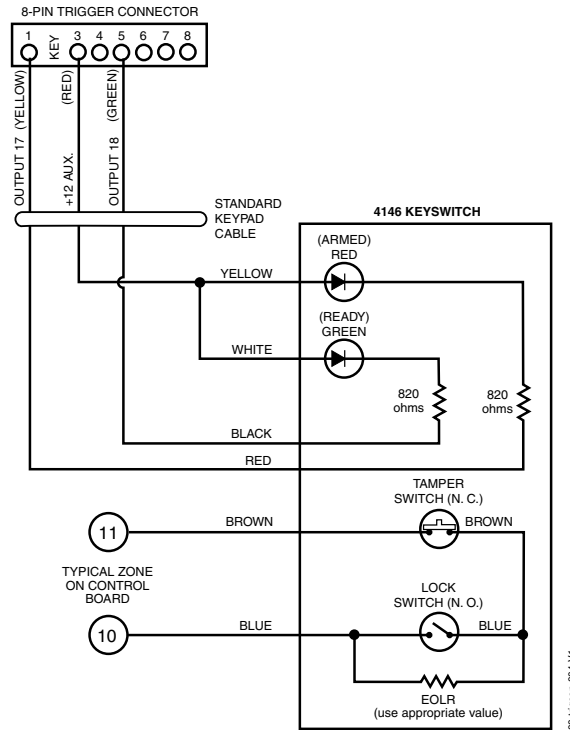

Figure 12. Keypad Wiring Connections

Keypad Notes

UL A UL Listed keyswitch is required for fire installations and UL commercial and residential burglar alarm installations. The Ademco 4146 keyswitch is UL Listed.

If a keyswitch is used on:

- an installation that transmits opening and closing signals, the keyswitch zone must be programmed to send opening and closing signals.
- a UL commercial burglar alarm installation, the keyswitch's tamper switch must be connected in to the alarm system. This tamper switch zone must also be programmed for Zone Type 05 – Trouble by Day / Alarm by Night.
- a fire alarm installation, the keyswitch must be located next to an alphanumeric display keypad.

- Use 4146 keyswitch or any N.O. keyswitch.
- Use only one keyswitch per partition.
- When using a keyswitch, the zone it is connected to is no longer available for use as a protective zone.
- Use *56 Menu mode to program the keyswitch zone and assign it zone type 77.
- Use *80 Menu mode to program the LED functions: program outputs 17 and 18 for system operation zone type 78 (red LED) and 79 (green LED) as appropriate (see **Output Device Programming** section).

Connecting Relay Modules, Powerline Carrier Devices and Output Triggers

4204/4229 Relay Modules

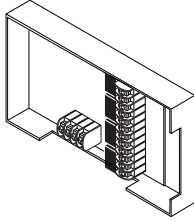

UL For UL installation requirements, refer to the Installation Instructions for the 4204.

1. Mount either remotely or in the control panel cabinet.
2. Connect each module to the control's keypad terminals and set the device addresses as previously described in the **Connecting Keypads and Other Addressable Device** section. Use the connector harness supplied with the module. Use standard 4-conductor twisted cable for long wiring runs.
 - Up to 16 relays (if no powerline carrier devices are used)
3. Connect the desired field wiring to the unit's relay contact terminals.

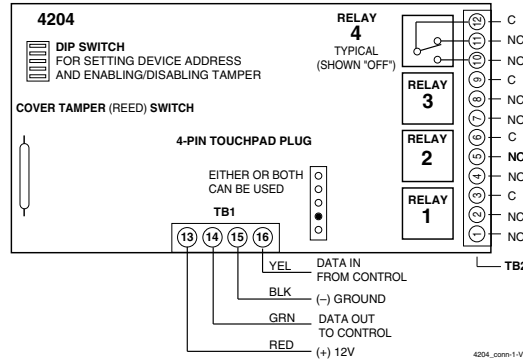

Figure 13. 4204 Connections to Control

- Supervision: 4204 and 4229 modules are supervised against removal. The module's device address is displayed as follows if a module is disconnected from the control's terminals, or if the module cover is removed and the tamper jumper is installed:

Alpha: CHECK xx Wire Expansion

FAULT xx Wire Expansion

ALARM xx Wire Expansion

Fixed-Glass: lxx (or 91 if field *199 set for 2-digit display)

where "xx" is the module's address.

- If communication/tamper failure occurs on a device with zones wired to it, all zones on the device will be displayed in their respective partitions.

Powerline Carrier Devices

UL Powerline Carrier devices and the 1361X10 Transformer are not UL Listed for fire or burglary functions and are intended for home automation.

1. Install the powerline carrier devices according to the instructions included with each.
 - Up to 16 devices (if no relays are used)
 2. Use Programming Mode to enter the device house ID in data field*27, and enter the unit code using *79 Output Device menu Mode.
 3. See connections diagram in the AC Wiring section for connecting the 1361X10 transformer to the triggers.
- You must use a 1361X10 Transformer instead of the 1361 Transformer.
 - The 1361X10 Transformer provides AC power to the control panel, and also supplies signals from the control panel through the premises AC wiring to the Powerline Carrier devices (which are plugged into AC outlets). You can then make devices that are plugged into Powerline Carrier devices perform various functions in response to commands you enter at the security system keypads.

Canada: Use the PSC04 Powerline Interface as shown below.

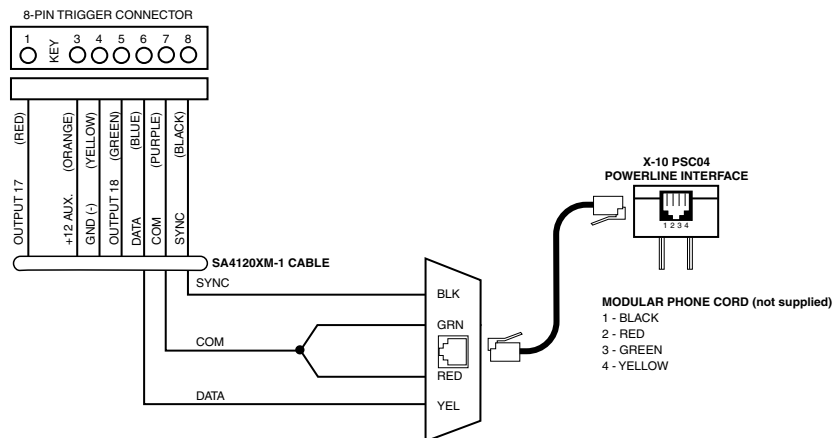

Figure 14. PSC04 Powerline Interface Connections (for Canadian Installations)

On-Board Triggers

Connect field wiring to the desired trigger pin on the 8-pin trigger connector centrally located above the terminal strip.

- If using 1361X10 transformer and powerline carrier devices, use the SA4120XM-1 cable (part of 4120TR Trigger Cable). See *Wiring the AC Transformer* section for transformer connections.
- If only using the on-board triggers, you can use a 4-wire cable (N4632-4, supplied with the control) as shown below.

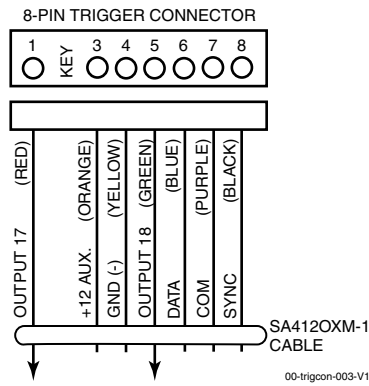

Figure 15a. On-Board Trigger Connector with SA4120XM-1 Cable for Use With 1361X10 Transformer

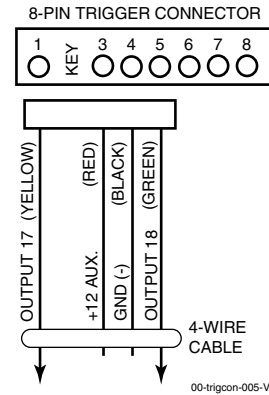

Figure 15b. On-Board Trigger Connector with 4-Wire Cable for Trigger Use Only

- Trigger outputs are normally high, and go low upon programmed condition.
- The outputs can be programmed for inverted operation (normally low, go high) using *79 Menu mode.
- Program these triggers using *80/*81 Menu modes as you would for any other relay output.
- When using these outputs, note:
 - pin 1 = output number 17 (trigger 1):
15 ohms to ground when closed (output low), open when off (output high, normal default); can be used to reset smoke detector power (must set “output normal low = yes” in *79 Menu mode, and set for zone type 54, fire zone reset, in *80 Menu mode); or can support 12V relay module (e.g., Altronix AX-RBS) that draws less than 100mA
 - pin 5 = output number 18 (trigger 2):
100 ohms to ground when closed (output low); open when off (output high, normal default); or can support 12V relay module that draws less than 20mA

UL If on-board triggers are used, the wiring between the control unit and the UL Listed device must be run in conduit, be no more than 3 feet apart, and have no intervening barriers or walls.

Phone Line/Phone Module, Audio Alarm Verification (AAV), and Internet (IP) Connections

Phone Line

Connect incoming phone line and handset wiring to the main terminal block (via an RJ31X jack) as shown in the Summary of Connections diagram at the back of this manual. Wire colors represent the colors of the cable to the RJ31X jack.

4286 Phone Module



Compatibility: 4286 Phone Modules must have software version WA4286-15.1 or higher (refer to the label on the square 4286 microprocessor chip).

UL The 4286 modules are UL Listed only for use on residential fire and UL residential burglar alarm installations.

1. Make 12V (+) and (-) and data in and data out connections from the phone module to the control, using the connector cable supplied with the phone module, then insert the keyed connector at the other end of the connector cable into the header on the phone module.
2. Connect Phone Module terminals as shown below. Use an RJ31X jack with a direct-connect cord and make all connections exactly as shown.
3. Caller ID Units: If a Caller ID unit is being used, connect the unit directly to the "Handset" terminals (21 & 22) on the control, as shown.

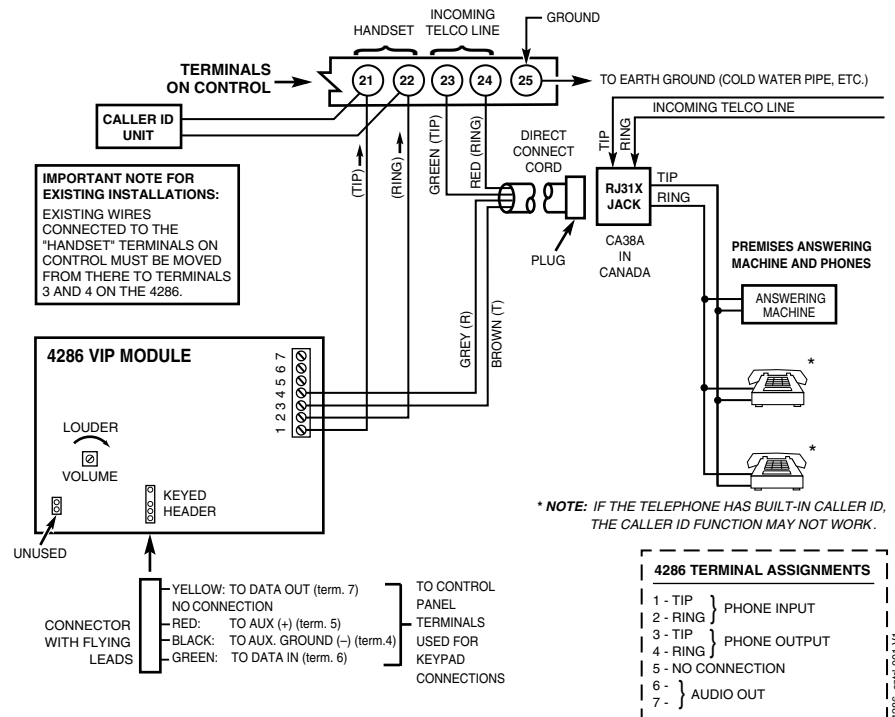

Figure 16. 4286 Phone Module Wiring Connections

- Only one phone module can be used and it can only be connected to partition 1.
- The phone lines must be in service for the phone module to function, even when accessing the system from an on-premises phone.
- If you are also using an Audio Alarm Verification (AAV) unit, refer to *Audio Alarm Verification (AAV)* section for special wiring connections.

CAUTION: To reduce the risk of fire, use only No. 26 AWG or larger telecommunication line cord for phone line connections.

Phone Module Problems

If no touch tones are produced following access to the security system from on-premises (this problem may arise in rare cases), it may be necessary to reverse the wires connected to terminals 3 and 4 on the phone module and the wires connected to terminals (21) & (22) on the control. The wiring diagram shows the wiring connections that will provide proper operation in most cases.

Connection to the incoming telco line via a RJ31X jack and direct-connect cord, as shown, is essential, even if the system is not connected to a central station. The 4286 will not function if this is not done and an error signal (fast busy signal) will occur when trying to access the system via the phone.

The house phone lines (gray and brown wires) must be wired to the phone module terminals; not to the control terminals. Otherwise, an error signal (fast busy signal) will occur when trying to access the system from an on-premises phone.

Audio Alarm Verification Connections (AVS System)

Using the AVS System with AVS Module and AVST Remote Stations

The AVS system provides audio alarm verification via the phone line. Refer to the instructions included with the AVS system for installation procedures. The following is a summary.

Mounting the AVS Base Unit

As shipped, the AVS Base unit board comes pre-mounted on its mounting bracket, which is designed to mount inside the control cabinet.

Refer to the diagram at right.

- a. Position the mounting plate/PC board assembly in the bottom of the control's cabinet.
- b. Slide the mounting plate to the right so that the plate's left-hand tang slides under the cabinet's tie-wrap loop.
- c. Secure the assembly to the cabinet using the two self-tapping screws provided.

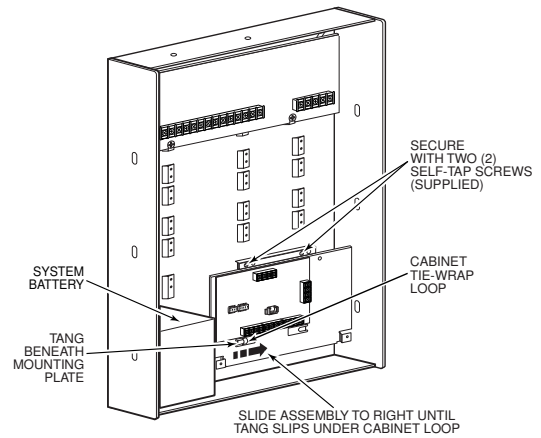

AVS-003-V0

BATTERY NOTE: When using a 7AH battery, mount the battery vertically on the bottom left-hand side of the cabinet, with the terminals facing down and right (negative terminal closest to the PC board bracket).

Wiring the AVS to the Control

The AVS Base unit board has several terminal blocks for making connections to remote stations, telephone lines, and to the control panel. The AVS base unit connects to the control's ECP terminals, with all other ECP devices connecting to the AVS base unit ECP terminals. See the diagram on the next page for specific wiring connections.

DIP Switch: Set the address AVS DIP switch to device address 11.

IMPORTANT: The AVS should be the only ECP device connected to the control's ECP terminals. Connect all other ECP devices (keypads, expander modules, etc.) to the ECP terminals on the AVS board.

The following summarizes the programming steps for AVS operation (refer to the Programming Guide for details of the AVS Quick Command options):

- a. Install the AVS module according to its instructions.
- b. Use one of the control's AVS Quick Program commands as follows :
 - **installer code + [#] + 03:** enable AVS operation without panel sounds on the AVST
 - **installer code + [#] + 04:** enable AVS operation and enable panel sounds on the AVST speaker
 - **installer code + [#] + 05:** remove all programming options set by [#] + 03 quick command
 - **installer code + [#] + 06:** remove all programming options set by [#] + 04 quick command
- c. Use data field *55 Dynamic Signaling Priority to select the desired reporting paths.

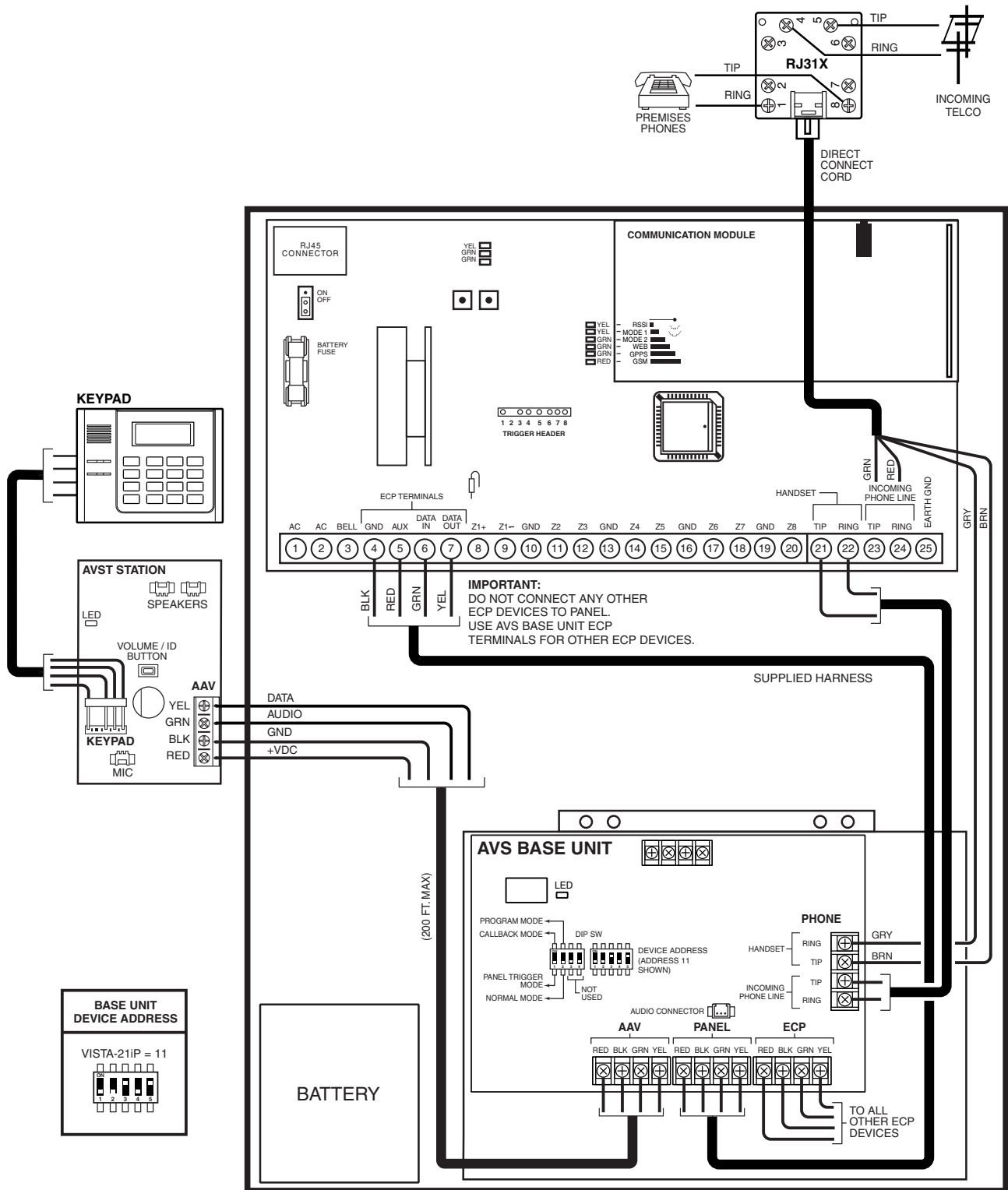

Figure 18. Connections for the AVS System

Internet (IP) Connection

Connection to the Internet can be made via hardwired high speed Internet connection and/or via an optional on-board VISTA-GSM4G module (using the wireless GSM digital cellular network). Use *29 Menu mode to program various internet reporting and supervision options.

Hardwire Internet Connection: Connect an active Ethernet cable (with RJ45 connector) to the IP connector on the upper left corner of the control board. The control must be registered before internet communication can occur. Refer to the Registering the Control section for details.

IMPORTANT! (1) Use of the Internet connection (hardwire or VISTA-GSM4G module) requires an AlarmNet-I account. If an account for the control does not yet exist, please obtain the account information from the central station prior to programming this module. (2) The control must be registered with AlarmNet before normal operation. See **Registering the Control with AlarmNet** section for registration procedures.

When the internet connection is active, the Network LEDs have the following functions:

IP (web) Network LED Functions

LED Color	LED	Description
Top Green	Ethernet Link/Activity	ON – link is active; OFF – no link
Middle Green	Link Speed	ON – 100 MB/S; OFF – 10 MB/S
Yellow	Network Collision	BLINK – collision detected; OFF – normal

VISTA-GSM4G module: See VISTA-GSM4G module Installation below.

VISTA-GSM4G Module Installation

General Information

The VISTA-GSM4G is an optional communication module and provides cellular radio communication with the AlarmNet network for delivery of alarm and other messages to the monitoring central station, and allows upload/download via the Internet using GSM technology in combination with Compass Downloading Software.

The VISTA-GSM4G module’s parameters are programmed using the control’s *29 Menu mode.

IMPORTANT! This device requires activation of its SIM card. See the SIM Activation Note in the **Registering the Control with AlarmNet** section later in this manual for the procedure.

Mounting the Module

IMPORTANT! Disconnect power from the control, including the battery, BEFORE installing the VISTA-GSM4G module.

CAUTION: ESD SENSITIVE DEVICE. To discharge any static buildup, briefly touch a chassis ground point before installing this module. Avoid performing this installation while standing on a carpeted floor.

1. Mount the VISTA-GSM4G Board.

- a. Push the three standoffs into the appropriate holes on the VISTA-21iP control board until they snap into place.
- b. Carefully align the VISTA-GSM4G board over the standoffs and the mating connector, then, **one at a time**, gently push down on the board near each standoff until it snaps into place and the connector is fully seated.
- c. After installation, affix the “Contains Transmitter Module” label (800-13423) to the outside surface of the control panel cabinet so it is visible.

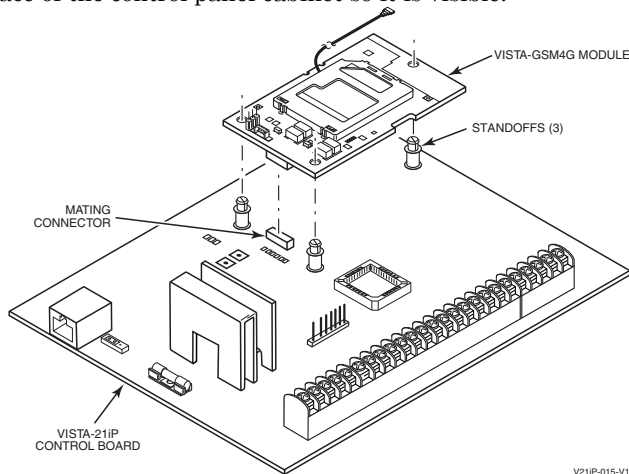

2. Install the Antenna Adapter Plate.

- Punch out the large wiring hole knockout and the adjacent smaller knockout from the cabinet's upper-right topside.
- Position the antenna adapter plate over the large knockout, aligning the plate's pin with the smaller knockout and push until the adapter snaps into place.
- Remove the nut and washer from the antenna adapter cable, then secure the cable's SMA connector to the adapter plate with the washer and nut as shown.

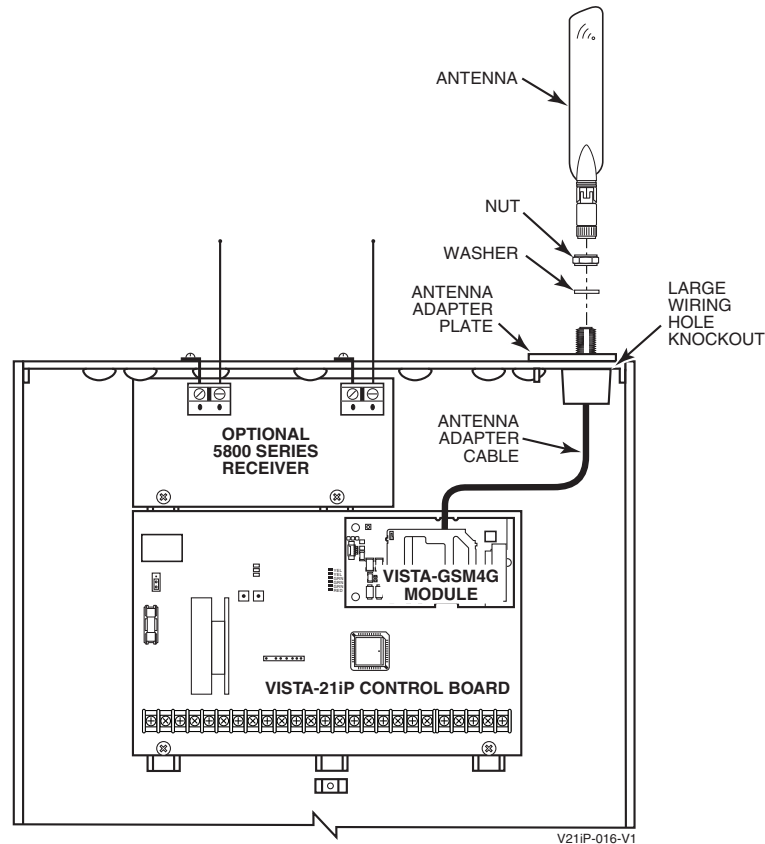

3. Install the Antenna.

The antenna mounts directly onto the antenna adapter cable at the antenna adapter plate.

Carefully align the antenna's connector over the SMA connector protruding from the adapter plate, then screw it down (clockwise) until it is finger tight. Do not over tighten.

	RF EXPOSURE WARNING
<p>The VISTA-GSM4G module must be installed to provide a separation distance of at least 7.8 in. (20 cm) from all persons and must not be co-located or operating in conjunction with any other antenna or transmitter except in accordance with FCC multi-transmitter product procedures.</p>	

Internal/External IP/GSM Power Jumper Note: After installation of the module, make sure the control's PC Board Internal/External IP/GSM Power Jumper is in the ON position (factory default position). The jumper is located below the RJ45 connector.

IP/GSM Status LEDs

There are three status LEDs used to indicate IP/GSM message and internal device status:

- STATUS, green
- MESSAGE, yellow
- FAULT, red

Each LED can have four different states - ON, OFF, FAST BLINK and SLOW BLINK.

IP/GSM Status LED Meanings

COLOR/LED	DESCRIPTION
Green Status	On – module NOT registered with AlarmNet Off – module is registered with AlarmNet Fast Blink – Download session with Compass in progress Slow Blink – In unison with yellow LED – Registration in progress.
Yellow Message	On – Message transmission pending. Quick Periodic Blink – Normal. Fast Blink – Message waiting for network ACK. Slow Blink – In unison with green LED – Registration in progress.
Red Fault	On – No contact with network. Off– Normal. Slow Blink – Loss of contact with panel (ECP fault). Fast Blink – No network contact AND loss of contact with the panel.
All	Fast Blink – In unison with the RSSI Bar Graph LEDs – Hardware Error. Call the AlarmNet Technical Assistance Center.

Signal Strength (RSSI)

RSSI is a measure of how well the VISTA-GSM4G is receiving the cell tower. For reliable service, the antenna should only be installed in locations where the RSSI is a minimum of three bars. The RSSI value can also be viewed on the keypad display by using the *shift <E>* command while in *29 Menu mode-Diagnostic mode.

The following are tips for maximizing signal strength:

- Find the best coverage before mounting the antenna by moving it to several locations while monitoring the RSSI.
- The best RSSI can usually be found on an exterior wall at the highest point in the building. Avoid the basement.
- Maintain at least 12 inches clearance between antenna and steel I-beams, HVAC ducts, metal studs, steel roofs, exterior walls with metalized insulation or aluminum siding and other large metal objects.

If a consistent RSSI of three bars cannot be found, the control cabinet may have to be moved to an area of better reception.

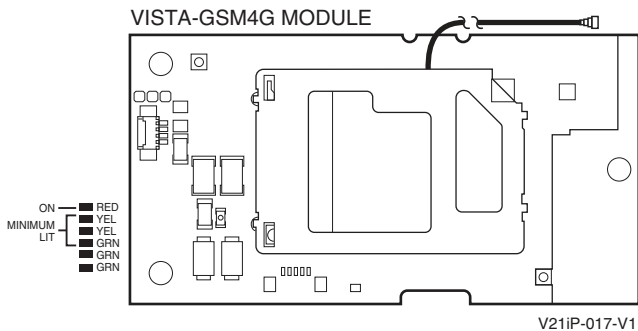

Signal Strength (RSSI) and Status LEDs

The Signal Strength (RSSI) Mode and Status LEDs normally display the module's signal strength†. LED 1 (top red LED) will be lit to indicate that the display is in RSSI mode, and the other LEDs indicate signal strength (lowest to highest, from top to bottom) between the module and the receiving tower. Signal strength should be within 3-5 bars.

† **NOTE:** The RSSI LEDs on the control board normally display signal strength **after** the SIM has been activated. If the SIM is not activated, signal strength can be viewed at these LEDs by simultaneously pressing and holding the TEST and STATUS switches on the control board.

Status Indicator Switch

Press and hold the Status LED Indicator Switch to change the LED functions to view the network carrier status. When the switch is held down, LED 1 (top red LED) will be off, and the other LEDs have the following meanings (see diagram for specific functions):

Signal Strength and Status LED Meanings

Color	Label	Indication
Red	RSSI	on = signal strength (RSSI) display off = status display
Yel (2)	mode	off = module operating in ECPmode
Green	Web	web connection status ON = connected to web OFF = no web connection
Green	GPRS	GPRS service availability ON = GPRS service available FLASH = GPRS in use OFF = no GPRS service (messages sent via SMS)
Green	GSM	network carrier registration status ON = registered with network carrier, no second site available FLASH = registered with network carrier and second site available, excellent RSSI BLINK = registered with network carrier and second site available, acceptable RSSI SLOW BLINK = registered with network carrier and second site available, low RSSI OFF = control not registered with network carrier

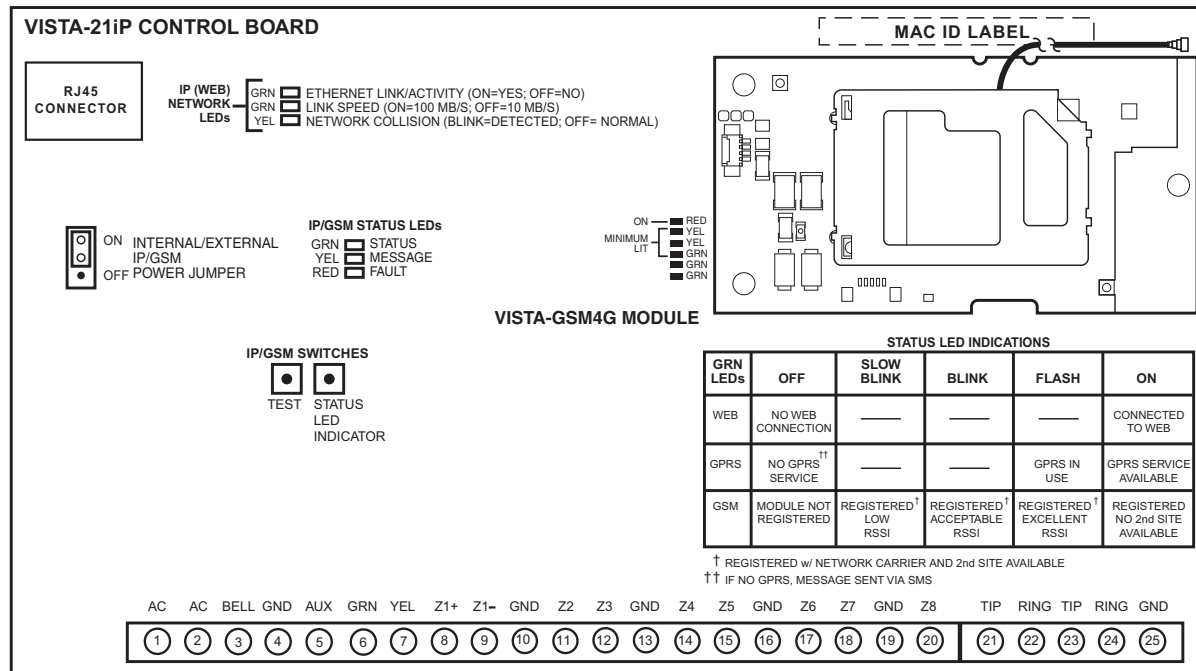

V21IP-018-V2

Signal Strength and Status LED locations – Status LED Functions Table

Inadequate Signal Strength; Using Stand-Alone Communication Device

If sufficient signal strength cannot be achieved, take one of the following actions:

1. Try relocating the cabinet to an area with better reception.
2. If moving the cabinet cannot achieve sufficient signal strength, an external, stand-alone communication device (ex. GSMV4G) can be used. Follow these steps:
 - a. Power down the control.
 - b. Remove the Internet cable from the RJ45 connector (if connected) and disable the Internal IP/GSM portion of the control board by moving the Internal/External IP/GSM Jumper to the OFF pair of pins.
 - c. Connect the communication device to the control's ECP terminals and complete all other communication device wiring as required.
 - d. Power up the control and the communication device.
 - e. Refer to *29 Menu mode, Enable INT IP/GSM prompt, for programming information.
 - f. Refer to the Installation and Setup Guide included with the communication device for the registration procedure.

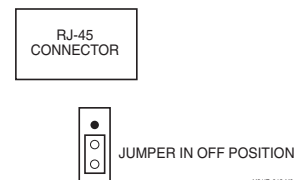

Programming Overview

About Programming

- You can program the system at any time, even at the installer's premises prior to the actual installation.
- Programming can also be performed remotely from the installer's office/home, using an IBM personal computer, a modem, and Compass downloading software.
- The Real-Time Clock must be set before completing the installation.

The following is a list of the various Programming modes used to program this system.

Programming Mode...	Used to ...
Data Field Programming	Program basic data fields used for setting the various system options. Most of the data fields in this system have been programmed for specific default values. However, some fields must be programmed for each particular installation to establish its specific alarm and reporting features.
*29 Menu Mode for IP/GSM	For programming the IP/GSM options.
*56 Zone Programming	Assign zone characteristics, report codes, alpha descriptors, and serial numbers for 5800 RF transmitters. See *56 Zone Programming in <i>Section 5. Menu Mode Programming</i> for procedures for programming zones.
*57 Function Key Programming	Program each of the four alphabet function keys to perform one of several system operations.
*58 Zone Programming (Expert Mode)	Similar to *56 mode, but provides a faster programming procedure and is intended for those more experienced in programming controls of this type.
*79 Output Device Mapping	Assign device addresses used by 4229 or 4204 Relay modules and map specific relays and device outputs, and assign unit codes for Powerline Carrier devices. See About Output Device Programming in <i>Section 5. Menu Mode Programming</i> for details on setting devices for manual/automatic operation.
*80 Output Definitions	Define up to 48 output definitions which can control the output relays mapped using *79 Output Device Mapping mode.
*81 Zone List Programming	Create Zone Lists for relay/powerline carrier zones, chime, night-stay, cross zones, and pager zones.
*82 Alpha Programming	Create alpha descriptors for easy zone identification.
Scheduling Mode (code + [#] +64)	Create schedules to automate various system functions.

Mechanics of Programming



To program the system from a keypad:

- You must use a 2-line Alpha display keypad.
- Both partitions must be disarmed.

Data Field Programming Procedures

Task	Procedure
Entering Program Mode	A) Press both [*] and [#] at the same time within 50 seconds after power is applied, OR B) After power-up, enter [Installer code (4-1-1-2)] + 8 0 0 (long beep indicates one of the partitions is armed and system cannot enter program mode). (method "B" is disabled if you exit Program mode using *98)
Go to a Data Field	Press [*] + [Field Number]. A display of "EE" or "Entry Error" means you have entered a nonexistent field. Simply re-enter [*] plus a valid field number.
Entering Data	When the desired field number appears, simply enter the digits required. The keypad beeps three times after the last digit is entered and automatically displays the next data field in sequence. If entering less than the maximum digits available (e.g., phone number field), enter the desired digits, then press [*] to end the entry.
Review a Data Field	Press [#] + [Field Number]. The field's data is displayed, but no changes can be made.
Deleting an Entry	Press [*] + [Field No.] + [*] (applies only to phone number, account number, and pager character fields).

Interactive Mode Programming (*56, *57, *58, *79, *80, *81, *82)

Entering Interactive Mode	Press [*] + [Interactive Mode No.] (for example, *56) while in Program Mode. The Alpha display keypad will display the first of a series of prompts. After making the appropriate entry, press the [*] key to accept the entry and continue to the next prompt.
---------------------------	---

Loading Factory Defaults/Initializing for Download

To Load Default Entries	Press *97 while in Program Mode. This resets all data fields to the default values shown on the Program Form. Use *97 only if you wish to return to the original factory-programmed defaults.
To Initialize Download ID	Press *96 while in Program Mode. This initializes the system for downloading and resets all the subscriber account numbers and CSID.

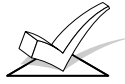

Do not press *97 to load defaults if any programming has been done previously—data already programmed into the system will be changed!

Exiting the Programming Mode

Prevent installer code reentry	Press *98. Exits Programming Mode and prevents re-entry by: Installer Code + [8] + [0] + [0]. To enter the programming mode if * 98 was used to exit, you must first power the system down. Then power up again, and press [*] and [#] at the same time, within 50 seconds of powering up. See field *88 for other Program mode lockout options.
Allow installer code reentry	Press *99. Exits Programming Mode and allows re-entry by: Installer Code + [8] + [0] + [0] or by: Pressing [*] and [#] at the same time, within 50 seconds of power-up.

Zone Type Definitions

Zone types define the way in which the system responds to faults in each zone.

Zone Type	Description
Type 00 Zone Not Used	Program a zone with this zone type if the zone is not used.
Type 01 Entry/Exit Burglary #1	<ul style="list-style-type: none"> Assign to zones that are used for primary entry and exit. Provides entry delay when zone is faulted if control is armed in the Away, Stay, or Night-Stay modes. No entry delay provided when the panel is armed in the Instant/Maximum mode. Entry delay #1 is programmable for each partition (field *35). Exit delay begins whenever the control is armed, regardless of the arming mode selected, and is programmable (field *34).
Type 02 Entry/Exit Burglary #2	<ul style="list-style-type: none"> Assign to zones that are used for entry and exit and require more time than the primary entry/exit point. Provides a secondary entry delay, in same manner as entry delay #1. Entry delay #2 is programmable for each partition (field *36). Exit delay is same as described for Type 01.
Type 03 Perimeter Burglary	<ul style="list-style-type: none"> Assign to all sensors or contacts on exterior doors and windows. Provides an instant alarm if the zone is faulted when the panel is armed in the Away, Stay, Night-Stay, Instant or Maximum modes.
Type 04 Interior Follower	<ul style="list-style-type: none"> Assign to a zone covering an area such as a foyer, lobby, or hallway through which one must pass upon entry (to and from the keypad). Provides a delayed alarm (using the programmed entry 1 time) if the entry/exit zone is faulted first. Otherwise this zone type gives an instant alarm. Active when the panel is armed in the Away mode. Bypassed automatically when the panel is armed in the Stay or Instant modes; if armed in Night-Stay mode, zones assigned to zone list 05 (night-stay zone list) are not bypassed when system armed in Night-Stay mode.

Type 05 Trouble by Day/ Alarm by Night	<ul style="list-style-type: none"> • Assign to a zone that contains a foil-protected door or window (such as in a store), or to a zone covering a sensitive area such as a stock room, drug supply room, etc. • Can also be used on a sensor or contact in an area where immediate notification of an entry is desired. • Provides an instant alarm if faulted when armed in the Away, Stay, Night-Stay, Instant or Maximum (night) modes. • During the disarmed state (day), the system will provide a latched trouble sounding from the keypad (and a central station report, if desired).
Type 06 24-hr Silent Alarm	<ul style="list-style-type: none"> • Usually assigned to a zone containing an emergency button. • Sends a report to the central station but provides no keypad display or sounding.
Type 07 24-hour Audible Alarm	<ul style="list-style-type: none"> • Assign to a zone that has an emergency button. • Sends a report to the central station, and provides an alarm sound at the keypad, and an audible external alarm.
Type 08 24-hour Auxiliary Alarm	<ul style="list-style-type: none"> • Assign to a zone containing an emergency button, or to a zone containing monitoring devices such as water or temperature sensors. • Sends a report to the central station and provides an alarm sound at the keypad. (No bell output is provided.)
Type 09 Supervised Fire	<ul style="list-style-type: none"> • Provides a fire alarm on short circuit and a trouble condition on open circuit. • A fire alarm produces a pulsing bell output and keypad sounding that complies with NFPA requirements for temporal pulse sounding of fire notification appliances. Fire alarm temporal pulse sounding is as follows: 3 pulses–pause–3 pulses–pause–3 pulses–pause. . . , repeated. • This zone type is always active and cannot be bypassed.
Type 10 Interior w/Delay	<ul style="list-style-type: none"> • Provides entry delay (using the programmed entry time), if tripped when the panel is armed in the Away mode. • Entry Delay 1 begins whenever sensors in this zone are violated, regardless of whether or not an entry/exit delay zone was tripped first. • Bypassed when the panel is armed in the Stay or Instant modes; if armed in Night-Stay mode, zones assigned to zone list 05 (night-stay zone list) are not bypassed when system armed in Night-Stay mode.
Type 12 Monitor Zone	<ul style="list-style-type: none"> • Works as a dynamic monitor of a zone fault/trouble (not alarm). In the case of a short/open, the message, "*ALARM*-24 Hr. Non-Burg. -#XXX " (where XXX is the zone number) will be sent to the Central Station. The system keypad will display a “check” message indicating the appropriate zone (but keypad beeping does not occur). Upon restoral of the zone, the message, "*RESTORE*-24 Hr. Non-Burg. -#XXX " will be sent to the Central Station. • The “check” message will automatically disappear from the keypad dynamically, when the zone restores; a user code + off sequence is not needed to reset the zone. • Faults of this zone type are independent of the system, and can exist at the time of arming without interference. • Since this is a “trouble” zone type, do not use this zone type with relays set to activate upon “alarm.”
Type 14 24 Hour Carbon Monoxide Monitor	<ul style="list-style-type: none"> • Assigned to any zone with a carbon monoxide detector. • A carbon monoxide alarm produces keypad and detector sounding (does not affect bell output) • Always active and cannot be bypassed.
Type 16 Fire w/Verification	<ul style="list-style-type: none"> • Provides a fire alarm when zone is shorted, but only after the alarm is verified to help eliminate false alarms due to electrical or physical transients. • System verifies alarm by resetting smoke detectors after short is detected (removes power 7 seconds for zone 1; 3 seconds for trigger output). A subsequent short circuit within 90 seconds triggers fire alarm, otherwise the first alarm is ignored. • Provides a trouble response when zone is open.
Type 20 Arm-Stay (BR only)	<ul style="list-style-type: none"> • Arms the system in Stay mode when the zone is activated. • Pushbutton units send the user number to the central station when arming or disarming. • User number for button must be assigned.
Type 21 Arm-Away (BR only)	<ul style="list-style-type: none"> • Arms the system in Away mode when the zone is activated. • Pushbutton units send the user number to the central station when arming or disarming. • User number for button must be assigned.
Type 22 Disarm (BR only)	<ul style="list-style-type: none"> • Disarms the system when the zone is activated. • User number for button must be assigned.

Type 23 * No Alarm Response	<ul style="list-style-type: none"> • Can be used on a zone when an output relay action is desired, but with no accompanying alarm (e.g., lobby door access).
Type 24 Silent Burglary	<ul style="list-style-type: none"> • Usually assigned to all sensors or contacts on exterior doors and windows where bells and/or sirens are NOT desired. • Provides an instant alarm, with NO audible indication at any keypad or external sounder, if the zone is faulted when the system is armed in the Away, Stay, Instant, or Maximum modes. • A report is sent to the central station.
Type 77 Keyswitch	<ul style="list-style-type: none"> • Assign to zone wired to a keyswitch. • Do not use devices assigned as input type “BR” with this zone type.
Type 81 AAV Monitor Zone (for AVS)	<ul style="list-style-type: none"> • Assign to zone connected to AVS module. • Monitors 2-way voice sessions as follows: <ul style="list-style-type: none"> - When the zone is faulted, all alarm sounding and dialer reporting stops, except for fire alarms, which immediately terminate the voice session and cause a fire report to be sent. - When the zone is restored (session ended), sounding resumes (if bell timeout has not expired) and reports that were stopped are sent.
Types 90-93 Configurable	<p>Allows for various custom responses. Options include response to entry/exit delays, response opens/shorts, types of alarm/trouble sounding, dial delay, and unique Contact ID report codes. Types 92 and 93 can only be programmed via downloader. UL installations: Zone Types 90 -93 may not be used as fire or burglar alarm zones on fire or UL burglar alarm installations.</p>

* The system can still be armed when these zone types are in a faulted condition.

NOTE: All of the zone types described are available for the wireless portion of the system, if used.

Data Field Programming

About Data Field Programming

The following pages list this control's data fields in numerical order. Valid entries for each field are shown in italics. Explanations and special notes are presented below the entries.



Use the separate Programming Guide to record the data for this installation.

Data field programming involves making the appropriate entries for each of the data fields. Start Data Field programming by entering the installer code + 8 0 0.

SIA Guidelines: Notes in certain fields give instructions for programming the VISTA-21iP for False Alarm Reduction. Fields unique to the **VISTA-21iPSIA** are indicated by heavy borders and reverse type heading "**V21iPSIA**" for easy identification.

System Setup Fields (*20 – *29)

*20 Installer Code

Enter 4 digits, 0000-9999

The Installer Code can perform all system functions except it cannot disarm the system unless it was used to arm the system. For security purposes, the factory default installer code should be changed.

*21 Quick Arm Enable

0 = do not allow quick arm; 1 = allow quick arm

If enabled, a user code is not needed to arm the system. Instead, users can press the [#] followed by an arming key to arm the system. However, the user code is always needed to disarm the system.

*22 RF Jam Option

0 = no RF jam detection; 1 = send RF jam report

If enabled, a report is sent if the system detects an RF jamming signal.

UL installations must be 1 if wireless devices are used.

*23 Quick (Forced) Bypass

0 = no quick bypass

1 = allow quick bypass (code + [6] + [#])

Zones bypassed by this function will be displayed after the bypass is initiated.

UL installations must be 0 (no forced bypass)

*24 RF House ID Code

00 = disable all wireless keypad usage

01–31 = House ID for partition 1, 2 and common

The House ID identifies receivers and wireless keypads. If a 5827 or 5827BD Wireless Keypad or 5804BD Transmitter is being used, a House ID code **must** be entered and the keypad set to the same House ID. You can assign RF house ID for each partition.

*26 Chime By Zone List/ KP Sound Enables

Entry 1

0 = no "entry 1" keypad trouble sounds, AND no chime by zone (keypad chimes on fault of any entry/exit or perimeter zone when chime mode is on)

1 = Chime by Zone enabled

2 = Communication Device (LRR) trouble sounding enabled (for devices such as GSMV)

4 = System Low Battery sounding enabled

7 = select all entry 1 options

*26 Chime By Zone List/ KP Sound Enables (continued)

Entry 2

0 = no "entry 2" keypad trouble sounds

1 = RF Supervision sounding enabled

2 = RF Low Battery sounding enabled

4 = RF Jam sounding enabled

7 = select all entry 2 options

Chime by Zone

If Chime by Zone is enabled (entry 1 – option 1), you can define the specific zones intended to chime when faulted while the system is in Chime mode. List chime zones on zone list 3 using *81 Menu mode.

Keypad (KP) Trouble Sounding

Keypad trouble sounding can be enabled/disabled for the conditions listed for each entry.

For each entry, enter the sum of the desired options. Example Entry 1: for Chime by Zone and System Low Battery sounding, enter 5. To enable all options, enter 7.

*27 Powerline Carrier Device (X-10) House ID

0 = A; 1 = B; 2 = C; 3 = D; 4 = E; 5 = F; 6 = G; 7 = H;

8 = I; 9 = J; # + 10 = K; # + 11 = L; # + 12 = M;

+ 13 = N; # + 14 = O; # + 15 = P

Powerline Carrier devices require a House ID, identified in this field. Program Powerline Carrier devices in interactive modes *79, *80 and *81. Not intended for fire or UL installations.

*28 Access Code for Phone Module

1-9 = first digit of access code

** or # = second digit of access code*

(# + 11 for "", or # + 12 for "#")*

You must assign a 2-digit access code for the 4286 Phone Module, if used. Example: If desired access code is 7*, then 7 is the first entry, and [#] + 11 (for *) is the second entry.

NOTE: A 0 in either digit disables the phone module. Must be 00 for UL Commercial Burglar Alarm installations.

*29 Menu Mode for IP/GSM Enable

For programming IP/GSM options. See *29 Menu Mode section for procedures.

Zone Sounds & Timing (*31–*39)

***31 Single Alarm Sounding Per Zone** (per armed period)
0 = no limit on alarm sounding per zone
1 = limit alarm sounding at the bell output to once per arming period for a given zone

V21iPSIA: If “0” selected, “alarm sounding per zone” will be the same as the “number of reports in armed period” set in field *93 (1 if one report, 2 if 2 reports, unlimited for zones in zone list 7).

***32 Fire Alarm Sounder Timeout**
*0 = yes; sounder timeout after time selected in field *33*
1 = no timeout; sounds until manually turned off

This control complies with NFPA requirements for temporal pulse sounding of fire notification appliances. Temporal pulse sounding for a fire alarm consists of the following: 3 pulses – pause – 3 pulses – pause – 3 pulses. UL fire alarm installations: must be 1.

***33 Alarm Sounder Timeout**
0 = No timeout; 1 = 4 min; 2 = 8 min; 3 = 12 min; 4 = 16 min

This field determines whether the external sounder will shut off after time allotted, or continue until manually turned off. UL Installations: For residential fire alarm installation, must be set for a minimum of 4 min (option 1); for UL Commercial Burglar Alarm installations, must be minimum of 16 min (option 4).

***34 Exit Delay**
00 - 96 = 0 - 96 seconds; 97 = 120 seconds

V21iPSIA: 45 - 96 = 45 - 96 secs; 97 = 120 secs
 NOTE: Entries less than 45 will result in a 45-sec delay.

The system waits the time entered before arming entry/exit zones. If the entry/exit door is left open after this time expires, an alarm will occur. Common zones use same delay as partition 1. UL installations: For UL Commercial Burglar Alarm and UL Residential Burglar Alarm installations with line security, total exit time must not exceed 60 seconds. SIA Guidelines: minimum exit delay is 45 seconds

***35 Entry Delay 1 (*35), Entry Delay 2 (*36)**
***36** *00 - 96 = 0 - 96 seconds; 97 = 120 secs; 98 = 180 secs; 99 = 240 secs*

V21iPSIA: 30-96 = 30 - 96 secs;
 97 = 120 secs; 98 = 180 secs; 99 = 240 secs
 NOTE: Entries less than 30 will result in a 30-sec delay.

Upon entering, the system must be disarmed before the time entered expires, otherwise it sounds an alarm. Common zones use same delay as partition 1. UL Installations: For UL Residential Burglar Alarm installations, must be set for a maximum of 30 seconds; entry delay plus dial delay should not exceed 1 min. For UL Commercial Burglar Alarm, total entry delay may not exceed 45 seconds. SIA Guidelines: minimum entry delay is 30 seconds

***37 Audible Exit Warning**
0 = no; 1 = yes
 Warning sound consists of slow continuous beeps until the last 10 seconds, and then it changes to fast beeps. Sound ends when exit time expires. SIA Guidelines: must be enabled (enter 1)

V21iPSIA: Feature always enabled; field does not exist.

***38 Confirmation Of Arming Ding**
0 = no ding; 1 = confirmation ding after arming system
2 = ding after arming from RF button or RF keypad only (except 5827/5827BD)

Confirmation of arming is 1/2-sec external sounder “ding.” If 1 selected, ding occurs when closing report is sent if open/close reporting is enabled, or at the end of Exit Delay. If 2 selected, ding occurs upon reception of the wireless arming command. UL Installations: must be 1 for UL Commercial Burglar Alarm installations.

***39 Power-Up In Previous State**
0 = always power-up in a disarmed state
1 = assume the system status prior to power down
 When the system powers up armed, an alarm will occur 1 minute after arming if a zone is faulted. Note that if the previous state was armed Away or Stay, the system ignores sensor changes for 1 minute, which allows sensors such as PIRs to stabilize. UL Installations: must be 1 (power-up in previous state) SIA Guidelines: must be 1

V21iPSIA: Feature must be enabled.

Dialer Programming (*40 – *50)

***40 PABX Access Code or Call Waiting Disable**
Enter up to 6 digits if PABX is needed to access an outside line. Do not fill unused spaces. 0–9, # + 11 for ‘’, # + 12 for ‘#’, # + 13 for a pause (2 seconds)*
 To clear entries from field, press *40*. If fewer than 6 digits need to be entered, exit by pressing [*].
Call Waiting: If the subscriber’s phone service has “call waiting” (and is not using PABX), enter “*70” (“# + 11”) plus “# + 13” (pause) as the PABX entry to disable “call waiting” during control panel calls. If the subscriber does not have “call waiting” and is not using PABX, make no entry in this field.
 NOTES: 1. The call waiting disable feature cannot be used on a PABX line. 2. Using Call Waiting Disable on a non-call waiting line will prevent successful communication to the central station.

V21iPSIA: If call waiting is used, enter call waiting disable digits as described above, and also set Call Waiting Disable option in field *91.

***41 Primary (*41) and Secondary (*42) Phone No.**

***42** *Enter up to 20 digits. 0–9, # + 11 = ‘*’, # + 12 = ‘#’, # + 13 = pause (2 secs)*
 If entering fewer than 20 digits, exit by pressing [*] + next field number. To clear entries, press *41* or *42* respectively. Do not fill unused spaces. NOTE: Backup reporting (see field *49) is automatic only if there is a secondary phone number (field *42).

43 Primary/Secondary Account Numbers**44** Enter 4 or 10 digits, depending on selection in***45** *48 Report Format field. Enter 0–9; # + 11 = B,***46** # + 12 = C, # + 13 = D, # + 14 = E, # + 15 = F.***43:** Partition 1 primary. To clear entries: *43*.***44:** Partition 1 secondary. To clear entries: *44*.***45:** Part. 2 prim. To clear entries: *45*.***46:** Part. 2 second. To clear entries: *46*.***47 Phone System Select**If Central Station Receiver **is not** on WATS line:

0 = Pulse Dial; 1 = Tone Dial

If Central Station Receiver **is** on WATS line:

2 = Pulse Dial; 3 = Tone Dial

Select the type of telephone service.

***48 Report Format (Primary/Secondary)**

0 = 3+1, 4+1 ADEMCO L/S STANDARD

1 = 3+1, 4+1 RADIONICS STANDARD

2 = 4+2 ADEMCO L/S STANDARD

3 = 4+2 RADIONICS STANDARD

5 = ADEMCO 10-digit Contact ID@

6 = 4+2 ADEMCO EXPRESS

7 = ADEMCO 4-digit Contact ID@

8 = 3+1, 4+1 ADEMCO L/S EXP.

9 = 3+1, 4+1 RADIONICS EXP.

Select format for primary/secondary phone numbers.

***49 Split/Dual Reporting**

0 = standard/backup reporting only (see Backup Reporting below)

To Primary No.	To Secondary No.
1 = alarms, restore, cancel	others
2 = all except open/close, test	open/close, test
3 = alarms, restore, cancel	all
4 = all except open/close, test	all
5 = all	all

Backup Reporting: All reports are sent only to the primary number unless unsuccessful after 8 attempts. If unsuccessful, the system will make up to 8 attempts to send all reports to the secondary number. If still unsuccessful after the 16 attempts, the system displays the “COMM. FAILURE” message (FC for fixed-word displays).

***50 Burglary Dialer Delay**

0 = no dial delay; 1 = 15 secs; 2 = 30 secs; 3 = 45 secs

UL: must be 0.

SIA Guidelines: delay must be minimum 15 seconds

V21iPSIA:**Delay Time:** 1 = 15 secs; 2 = 30 secs; 3 = 45 secs**Delay Disable:**

0 = use delay set in entry 1

1 = dial delay disabled for zones listed in zone list 6 (use zone list 6 to enter those zones that require dial delay to be disabled; these zones ignore the setting in entry 1)

UL: Dial delay plus entry delay must not exceed one minute; use zone list 6 to disable dial delay from appropriate zones, if necessary.

Provides delay of “BURGLARY ALARM” report to the central station, which allows time for the subscriber to avoid a false alarm transmission. This delay does not apply to zone type 24 alarms (silent burglary) or to 24-hour zone types 6, 7, and 8 (silent panic, audible alarm, auxiliary alarm), which are always sent as soon as they occur.

***53 SESCOA/Radionics Select**

0 = Radionics (0-9, B-F); 1 = SESCOA (0-9 only)

Select SESCOA or Radionics format.

Select 0 for all other formats.

***54 Dynamic Signaling Delay**

0 = disabled (both signals sent);

1–15 = entry times a 15-second delay.

e.g., 1 = 15 seconds, 2 = 30 seconds, etc.

Intended for use with IP/GSM reporting.

This field lets you select the time the panel should wait for acknowledgment from the first reporting destination (primary dialer or IP/GSM; see *55) before it attempts to send a message to the second destination. Delays can be selected from 0 to 225 seconds, in 15-second increments. This delay is per message. If 0 is entered in this field, the control panel will send redundant reports to both Primary Dialer and IP/GSM.

NOTE: If *55 is set to “0,” use minimum of 30 seconds to avoid redundant IP report. However, this value may need to be adjusted (ex. 45 secs) depending on the reporting environment.

UL Installations:

For UL Burglar Alarm installations with Line Security, Dynamic Signaling Delay must be 0. Reports will be sent to both the dialer and the IP/GSM.

***55 Dynamic Signaling Priority / AAV Enable**

0 = Primary Dialer first / using AAV via phone line

1 = IP/GSM module first for alarm reports / not using AAV

This field selects the primary communication path (dialer or communication device) for reporting of primary phone number events† (see *49 Split/Dual Reporting) and if used, enables AAV (AAV sessions use the phone line only).

Use *29 IP/GSM menu mode to enable the communication device being used.

† Reports intended for the secondary phone number are not sent via the communication device.

For Dynamic Signaling Priority: Select the initial reporting destination for messages as follows:

Primary Dialer First selected (0):

- If acknowledged before delay expires (see *54), then message will not be sent via LRR.
- If not acknowledged before delay expires, message is sent to both the Primary Phone No. and via LRR.

Communication Device First (LRR) selected (1):

- If acknowledged before delay expires, then message will not be sent to the primary dialer.
- If not acknowledged before delay expires, message is sent to both the Primary Phone No. and via LRR.

For AAV Path Select:

- If using the AVS system, option 0 (primary dialer first) must always be used; AAV sessions can occur only over the phone line with this control.

***56 Zone Programming Menu Mode**

For programming zone information.

See Zone Programming section for procedures.

***57 Function Key Menu Mode**

For programming keypad function keys.

See Function Key section for procedures.

***58 Expert Zone Programming Menu Mode**

For quickly programming zone information, but is recommended only for those already familiar with *56 menu mode. See Zone Programming section.

System Status Report Codes

Zone report codes are programmed using interactive *56 or *58 Zone Programming modes, while system status (non-alarm) codes and restore codes are entered in data fields *59 - *68, *70 - *76, *89. The actual report code digits that you enter depend upon the particular installation, and should agree with the Central Station office receiving the signals.

3+1 or 4+1 Standard Format: Enter a code in the first box: 1-9, A, B, C, D, E, or F. Enter #+10 for A (this reports a 0 on some receivers), #+11 for B, #+12 for C, #+13 for D, #+14 for E, #+15 for F.

An entry of 0 in the first box disables a report. Entering 0 in the second box advance to the next field.

Expanded or 4+2 Format: Enter codes in both boxes (first/second digits) for 1-9 or A-F, as described above. A 0 in the first box disables a report. A 0 in the second box eliminates the expanded message for that report.

ADEMCO Contact ID® Reporting: Enter a digit in the first box to enable the zone to report. Use a different digit for each zone until you have used up available digits. If the number of zones exceeds the number of available digits, begin with digit 1 again. This is an “enabling” code only and is not the actual code sent to the Central Station office. Entries in the second boxes are ignored. An entry of 0 in the first box disables the report.

UL Report codes are required in fields *61, *65, *71, *72, for UL Commercial Burglar Alarm installations. Report codes are required in fields *60, *62, *63, *64, *70, *73, *74, *75, *76, for UL Commercial Burglar Alarm installations and required for Residential Fire Alarm installations.

***59 Exit Error Report Code**

0 = no report; 1-F = see description above

V21iPSIA: [1] Always enabled. Also see field *69.

After arming the system, entry/exit and interior zones remaining open after exit delay expires cause an alarm sound at the keypad and external sounder (keypad also displays “EXIT ALARM”), and entry delay begins. Disarming before the end of the entry delay stops the alarm sounding and no message is sent to the central station. The keypad will display “CA” (fixed-word) or “ALARM CANCELED” (alpha display).

If the system is not disarmed before entry delay expires, an “EXIT ALARM” message (**V21iPSIA**; also zone alarm message) will be sent to the central station. The keypad will display “EA” (fixed-word) or “EXIT ALARM” (alpha display), and alarm sounding continues until the system is disarmed (or timeout occurs).

An Exit Alarm condition will also result if a fault occurs in an exit or interior zone within 2 minutes following the end of the exit delay, and an “EXIT ALARM” message will be sent to the central station (except for **V21iPSIA**, see field *69 Recent Closing report). With Contact ID format, the message will contain the zone number and error code 374 (“ALARM-EXIT ERROR”).

***60 Trouble Report Code**

0 = no report; 1-F = see description above *59

Sent if a zone has a trouble condition. See UL System Reporting Note above *59.

***61 Bypass Report Code**

0 = no report; 1-F = see description above *59

Sent when a zone is manually bypassed. See UL System Reporting Note above *59.

***62 AC Loss Report Code**

0 = no report; 1-F = see description above *59

Timing of this report is random with up to a 4-hour delay. If AC restores before the report goes out, there is no “AC LOSS” report. See UL System Reporting Note above *59.

***63 Low Bat Report Code**

0 = no report; 1-F = see description above *59

Sent when the system’s backup battery has a low-battery condition. See UL System Reporting Note above *59.

***64 Test Report Code**

0 = no report; 1-F = see description above *59

Sent periodically to test that the communicator and phone lines are operational. See System Reporting UL Note above *59. Frequency of report is set in Scheduling mode (event 11) or by the following key commands:

- installer code + [#] + 0 + 0 = test report sent every 24 hrs
- installer code + [#] + 0 + 1 = test report sent once per week
- installer code + [#] + 0 + 2 = test report sent every 28 days

Each of these modes sets schedule 32 to the selected repeat option; first test report sent 12 hours after command†.

† **NOTE:** Make sure the Real-Time Clock is set to the proper time **before** entering the test report schedule command to ensure that test reports are sent when expected. (see Setting the Real-Time Clock section)

***65 Open Report Code**

0 = no report; 1-F = see description above *59

Sent upon disarming the system in the selected partitions. See UL System Reporting Note above *59.

***66 Arm Away/Stay Report Code**

0 = no report; 1-F = see description above *59

This option allows for independent programming of Away and Stay reports for each partition, including the common lobby.

NOTE: “OPEN” reports are not sent if the associated closing report is not enabled.

***67 RF Trans. Low Batt. Report Code**

0 = no report; 1-F = see description above *59

Sent when a transmitter low-battery condition exists. UL installations: must be enabled if wireless devices are used.

***68 Cancel Report Code**

0 = no report; 1-F = see description above *59

Sent upon disarming the system after an alarm condition was reported.

V21iPSIA: [10] Report enabled.

***69 Recent Closing Report** **V21iPSIA only**

Always enabled. Field does not apply to other controls.
 Similar to the Exit Error condition described in field *59, but occurs if any burglary zone is faulted within two minutes **after** the initial exit delay expires. Disarming the system within the two minutes stops the alarm sound and displays "ALARM CANCELED " or "CA" and the faulted zone number. No message is sent to the Central Monitoring Station.
 If the system is not disarmed within two minutes, the alarm sound continues and a "recent closing" and a "zone alarm" message are sent to the Central Monitoring Station (after dial delay expires).

***70 Alarm Restore Report Code**

*0 = no report; 1-F = see description above *59*
 See UL System Reporting Note above *59.

Alarm restore signals indicate that respective alarm zone(s) are no longer faulted. Alarm restore reports are sent to the central station at bell timeout (field *33), if the zone(s) in alarm are actually restored to a non-faulted state at that time. Otherwise, alarm restore report(s) for respective alarm zones are sent when the system is disarmed.

***71 Trouble Restore Report Code**

*0 = no report; 1-F = see description above *59*
 Sent when a zone trouble is restored and code + OFF performed. See UL System Reporting Note above *59.

***72 Bypass Restore Report Code**

*0 = no report; 1-F = see description above *59*
 Sent when a zone that has been bypassed is unbypassed. See UL System Reporting Note above *59.

***73 AC Restore Report Code**

*0 = no report; 1-F = see description above *59*
 Sent after AC power has been restored after an AC power outage. See UL System Reporting Note above *59.

***74 Low Bat Restore Report Code**

*0 = no report; 1-F = see description above *59*
 Sent after a system low-battery condition is restored to normal. See UL System Reporting Note above *59.

***75 RF Xmtr Low Batt. Restore Code**

*0 = no report; 1-F = see description above *59*
 Sent when a transmitter's low battery condition is restored (i.e., new battery installed).
 UL: must be enabled if wireless devices are used. See UL System Reporting Note above *59.

***76 Test Restore Report Code**

*0 = no report; 1-F = see description above *59*
 This is sent when the Test mode is exited or upon timeout. See UL System Reporting Note above *59.

Miscellaneous System Fields***77 Daylight Saving Time Start/End Month**

0 = Disabled; 1 = Jan; 2 = Feb; 3 = Mar; 4 = April; # + 10 = Oct; # + 11 = Nov; # + 12 = Dec
 Enter the start and end month for daylight saving time, if applicable to the region.

***78 Daylight Saving Time Start/End Weekend**

0 = disabled; 1 = first; 2 = second; 3 = third; 4 = fourth; 5 = last; 6 = next to last; 7 = third to last
 Enter the start and end weekend for daylight saving time, if applicable to the region.

***79 Output Device Mapping Menu Mode**

Use this menu mode to enter output devices/powerline carrier devices into the system. See Output Device Programming section for procedures.

***80 Output Programming Menu Mode**

Use this menu mode to define output functions for use with output devices/powerline carrier devices. See Output Programming section for procedures.

***81 Zone List Programming Menu Mode**

Use the menu mode to define zone lists. See Zone List Programming section.

***82 Alpha Descriptor Programming Menu Mode**

Use this menu mode to assign alpha descriptors to zones and/or create partition descriptors.

***84 Auto-Stay Arm**

0 = no; 1 = partition 1 only; 2 = part. 2 only; 3 = both parts.
 If enabled, the system will automatically change AWAY mode to STAY mode if the entry/exit door is **not** opened and closed within the exit delay time after a user arms in AWAY mode from a wired keypad (non-RF device). An Opening report followed by an Armed Stay report is sent to the Central Station.

If the door is opened and closed within the exit delay period, the system remains in AWAY mode.

Any RF device that arms the system AWAY overrides this feature and the system remains armed AWAY.

***85 Cross Zone Timer**

<i>0 = 15 secs</i>	<i>4 = 90 secs</i>	<i>8 = 4 min</i>	<i>#+12 = 8 min</i>
<i>1 = 30 secs</i>	<i>5 = 2 min</i>	<i>9 = 5 min</i>	<i>#+13 = 10 min</i>
<i>2 = 45 secs</i>	<i>6 = 2-1/2 min</i>	<i>#+10 = 6 min</i>	<i>#+14 = 12 min</i>
<i>3 = 60 secs</i>	<i>7 = 3 min</i>	<i>#+11 = 7 min</i>	<i>#+15 = 15 min</i>

Sets the maximum amount of time in which two cross zones must be tripped in an armed system to send an alarm message to the Central Station. If only one cross zone is tripped during this time, a trouble message (CID code 380) for that zone is sent to the Central Station.

Assign cross zone pairs in zone list 4.

This option not for use in UL installations.

NOTE: Cross zoning takes effect only after Exit Delay expires.

***86 Cancel Verify Keypad Display**

0 = no "alarm canceled" display
1 = display "Alarm Canceled" when system is disarmed after an alarm has occurred. (To clear the "ALARM CANCELED" display, the user must enter the security code + OFF again.)

This feature causes a "ALARM CANCELED" display on the LCD keypad under the following conditions:

- After the kissoff of the cancel message to the Central Station, indicating a successful transmission.
- When an alarm is successfully canceled before the Central Station received the Alarm message. E.g., if an alarm is incorrectly triggered and the user presses code + OFF before the dial delay time has expired, the message will never go out to the CS.
- When the Cancel report is not enabled and the system is disarmed:
 - a. **before** dialer delay expires (alarm report not sent) message "Alarm Canceled" is displayed.
 - b. **after** dialer delay expires message "Alarm Canceled" is not displayed.

***87 Misc. Fault Delay Time**

0 = 15 secs 4 = 90 secs 8 = 4 min #+12 = 8 min
 1 = 30 secs 5 = 2 min 9 = 5 min #+13 = 10 min
 2 = 45 secs 6 = 2-1/2 min #+10 = 6 min #+14 = 12 min
 3 = 60 secs 7 = 3 min #+11 = 7 min #+15 = 15 min

Used with zones assigned to a configurable zone type with fault delay on (configurable zone type digit "6"), and sets a zone response time of 15 seconds to 15 min. It can be assigned to zones with sensors that provide a trouble indication when an oil tank is low, or similar applications for critical condition monitoring where a non-alarm response is desired.

UL: May only be used on non-burglar alarm and non-fire alarm zones when used on a fire and/or UL burglar alarm installation.

***88 Program Mode Lockout Options**

0 = standard *98 installer code lockout
 1 = lockout [*] + [#] reentry after *98 exit (reentry via installer code only)
 2 = lockout all local programming after *98 exit (reentry via downloader only)

The following table summarizes the Program mode lockout options:

Exit Command	*88 Entry	Reentry By:		
		Installer	Power-up†	Downloader
*99	n/a	yes	yes	yes
*98	0	no	yes	yes
*98	1	yes	no	yes
*98	2	no	no	yes

† pressing [*] + [#] within 50 seconds of power up

***89 Event Log Full Report Code**

0 = no report; 1-F = see description above *59

If an Event Logging selection is made in field *90, a message can be sent to the central station receiver when the log is 80% full. If the log becomes full, new messages overwrite the oldest messages in the log.

***90 Event Log Enables**

0 = no event logging; 1 = log Alarm and Restore; 2 = log Trouble and Restore
 4 = log Bypass and Restore; 8 = log Open/Close
 x = log combination of events (add value of entries)

This system can record up to 100 system events in a history log. At any time, the downloader operator can then upload the log and view or print out all or selected categories of the log. The downloader operator can also clear the log. Event log can also be viewed at an alpha keypad. The display/printout at the central station will show the date, time, event, and description of the occurrences.

Data Entry Example: To select Alarm/Alarm Restore" and "Open/Close", enter 9 (1+ 8); to select all events, enter #15.

***91 Option Selection / Remote Interactive Services (RIS) Enable**

Entry 1: Options

0 = none
 1 = Bell Supervision Processing†
 4 = using Audio Alarm Verification (AAV) unit
 8 = Enable Exit delay restart/reset ††

Entry 2: Remote Interactive Services (RIS) enable

0 = RIS disabled
 1 = not applicable
 2 = RIS enabled

V21iPSIA:

Entry 1 Options: Same as above.

Entry 2 Call Waiting Disable / RIS Enable:

0 = call waiting not used
 1 = use call waiting disable digits (*70) entered in field *40; (when selected, the system dials the entry in *40 only on alternate dial attempts; this allows proper dialing in case call waiting service is later canceled by the user).
 2 = RIS (Remote Interactive Services) enabled
 3 = Call Waiting disable and RIS enabled

Select by adding the values of each option. E.g., for both AAV and Exit delay restart, enter # + 12 (4 + 8).

†† "Exit Delay Restart/reset" option allows use of the [*] key to restart the exit delay at any time when the system is armed STAY or INSTANT. This feature also enables automatic exit delay reset, which resets exit delay if the entry/exit door is re-opened and closed before exit delay time expires after arming AWAY. Automatic Exit Delay Reset occurs only once during an armed AWAY period.

IMPORTANT: AAV should not be used when Paging or Alarm Reports are sent to a secondary number unless the monitoring zone option is used (which pauses calls). Otherwise, the call to the secondary number by the communicator after the alarm report will prevent the AAV from taking control of the telephone line, and the AAV "Listen in" session cannot take place.

Remote Interactive Services (RIS) Enable: This option enables enhanced Remote Interactive Services (RIS), if supported by the communication service in use. If enabled, device address 25 is automatically assigned.

UL UL installations using the AAV feature must use the Honeywell AVS system. Exit Delay Restart/Reset must be disabled.
SIA Guidelines: Exit delay should be enabled.

***92 Phone Line Monitor Enable**

Entry 1–Timeout:

0 = disabled; 1-15 = 1 minute to 15 minutes respectively (2 = 2 min, 3 = 3 min, etc.; # + 10 = 10 min, # + 11 = 11 min, # + 12 = 12 min, # + 13 = 13 min, # + 14 = 14 min, # + 15 = 15 min)

Entry 2–Display/Sound:

0 = keypad display only when phone line is faulted.
 1 = keypad display plus keypad trouble sound when line is faulted. Each partition turns off its own trouble sound. No automatic timeout.
 2 = Same as "1" plus programmed output device STARTS. If either partition is armed, external sounder activates. External sounder will be turned off by normal bell timeout, or by security code plus OFF from either partition (it does not have to be the one that was armed).

***92 Phone Line Monitor Enable (continued)**

Entry 1: Sets the length of time a phone line fault must remain after detected before the second digit option is activated.

Entry 2: Selects the desired phone line fault response. Option 2 may be used even if a relay unit or Powerline carrier device is not connected to the control.

If option 2 used, programmed Output Device must either be programmed to be STOPPED in field *80 or STOPPED by entry of [security code] + [#] + 8 + device number. Partition in *80 should be set to "0," for STOP.

UL Field *92 must be enabled for fire alarm installations, UL commercial burglar alarm installations and UL residential burglar alarm installations.

If the control unit is used on a UL commercial burglar alarm system which requires 2 methods of remote communication, then the control unit's DACT and the other method of signal transmission must monitor each other against communication failure and line fault. The fault must be received and annunciated within 200 seconds of its occurrence.

***93 No. of Reports In Armed Period per Zone (Swinger Suppression)**

0 = unlimited number of reports

1 = 1 report pair per zone per armed period

2 = 2 report pairs per zone per armed period

Selection limits the number of alarm/restore message pairs per zone sent to the CS in an armed period and applies to burglary zones only.

SIA Guidelines: Must be set for option 1 or 2.

V21iPSIA:

Report Pairs: 1 = 1 report pair; 2 = 2 report pairs

Unlimited Reports Enable:

0 = restrict reports to the setting in entry 1

1 = unlimited reports for zones listed in zone list 7; (use zone list 7 to list zones that require unlimited reporting; these zones ignore the setting in entry 1)

***94 Download Phone Number**

Enter up to 20 digits as follows: 0-9, # +11 for "*", # + 12 for "#", # + 13 for a pause.

Enter the phone number of the downloading computer. Do not fill unused spaces. End field by entering *. To clear entries from field, press *94*.

UL: Up/downloading via phone line may be performed only if a technician is at the site.
Up/downloading via the Internet has not been evaluated by UL.

***95 Ring Count For Downloading**

0-15 = number of rings before control picks up phone line.

Refer to the chart below and program accordingly.

phone module	answer machine	down-loading	Set field *95 to...
yes	no	no	1-14 (not 0)
yes	yes	no	higher than number of rings set on answer machine (e.g., if ans. machine is 4 rings, set this field to 5). This allows access to the phone module if the answer machine is off.
yes	no	yes	1-14 (not 0)
yes	yes	yes	15 (bypasses answer machine†)
no	no	no	0
no	yes	no	0
no	no	yes	1-14
no	yes	yes	15

† **NOTE:** If "15" is entered to bypass an answering machine, and a 4286 Phone Module is included in the system, you should note the following:

When calling in from an off-premises phone, the user should make the initial call, allow 1 or 2 rings only, then hang up, then call again. The phone module will now seize the line, and 2 long tones sound, followed by the usual voice prompt for the access code. If this procedure is not followed, phone module operation will not be possible.

***96 Command to Initialize CSID and Subscriber Account Number**

Use this command, if necessary, to reset all subscriber account numbers and the internal CSID to the factory default values.

***97 Command to Reset System to Factory Default Values**

Pressing *97 resets all data fields to the factory default values (shown on the Program Form).

IMPORTANT: Do not press *97 to load defaults if any programming has been done previously—data already programmed into the system will be changed!

***98 Command to Exit Program Mode (with installer code lockout)**

Exits Programming Mode and prevents re-entry by: Installer Code + [8] + [0] + [0].

To enter the programming mode if * 98 was used to exit, you must first power down the system. Then power up again, and press [*] and [#] at the same time, within 50 seconds of powering up. See field *88 for other Program mode lockout options.

***99 Command to Exit Program Mode**

Exits Programming Mode and allows re-entry by: Installer Code + [8] + [0] + [0] or by: Pressing [*] and [#] at the same time, within 50 seconds of power-up.

Pager Programming Fields

The system can send various reports to up to four pagers.

To program pager reporting, do the following:

1. Enter the pager phone number(s), preface characters, and pager report options in data fields *160 - *171:
2. Enable Pager Delay, if desired, in field *172 (delays alarm reporting for ALL pagers).
3. Make sure appropriate user open/close pager reports are enabled (see Security Codes, Assigning Attributes in **Section 6. System Communication and Operation**). Users that perform actions in partition 1 will, if enabled, attempt to report to all pagers enabled for open/close reporting in partition 1. Users that perform actions in partition 2 will, if enabled, attempt to report to all pagers enabled for open/close reporting in partition 2.
4. If using latchkey pager report, define the latchkey report schedule using Scheduling mode (master code + [#] [6] [4] then select event type 03). System must be armed for the Latchkey report to be sent.
5. If using a function key to manually send a message to a pager, use *57 Function Key Menu mode to define the key (function 01).
6. If reporting zone alarms and troubles to a pager, use *81 Zone List menu mode to assign the zones associated with each pager (zone lists 9-12).

***160 Pager 1 Phone No.**

Enter up to 20 digits.

If entering fewer than 20 digits, exit by pressing [*] + next field number. To clear entries, press *160*.

***161 Pager 1 Characters**

Enter up to 16 characters.

Up to 16 optional characters may be sent as a prefix to the 7-digit system status code sent to Pager #1 (if used). Phone number in field *160 must have been entered. If fewer than 16 characters, exit by pressing [*] and next field number. To clear entries: press *161*.

The 16 characters may be composed of the following:

- PIN number, Subscriber account number,
- * (enter # + 11 to send *), # (enter # + 12 to send #),
- Pause (enter # + 13 to allow a 2-second pause),†
- special character(s) the user may decide to transmit

† Some paging systems require pause(s) before the prefix.

The Pager format for the 7-digit status code is defined as follows: XXX-YYYY where:

- XXX = 3-digit event code: 911 = Alarm, 811 = Trouble, 101 = Opening (disarm), 102 = Closing (arm AWAY)

YYYY = 4-digit user or zone number (depending on type of event). The first digit indicates partition (0 = system, 1 = part 1, 2 = part 2, 3 = common), followed by the 3-digit user or zone number.

Display Example 1. 9 1 1 – 1 0 0 4 Indicates an alarm (911) caused by a fault in zone 4 (0004) in part. 1.

Display Example 2. 1 0 2 – 2 0 0 5 Indicates the system is reporting a closing-system arming (102) by User 5 (0005) in partition 2.

***162 Pager 1 Report Options**

0 = No reports sent; 1 = Open/close for all users enabled to page†; 4 = All alarms and troubles

5 = All alarms, troubles, and open/close for all users enabled to page

12 = Alarms and troubles for zones entered in zone list 9

13 = Alarms and troubles for zones listed in zone list 9 and open/close for all users enabled to page

Enter the types of reports to be sent to Pager 1 for each partition.

† For users enabled for paging. Reports to pager only when arming (close)/disarming (open) from a keypad using a security code; auto-arming/disarming, arming with assigned button, and keyswitch arming do not send pager messages.

***163 Pager 2 Phone No.**

up to 20 digits

If entering fewer than 20 digits, exit by pressing [*] + next field number. To clear entries, press *163*.

***164 Pager 2 Characters**

up to 16 characters

See field *161 for explanation of entries. If fewer than 16 characters, exit by pressing [*] and next field number. To clear entries, press *164*.

***165 Pager 2 Report Options**

See pager 1 reports, field *162 for entries, except use zone list 10

***166 Pager 3 Phone No.**

Enter up to 20 digits

If entering fewer than 20 digits, exit by pressing [*] + next field number. To clear entries, press *166*.

***167 Pager 3 Characters**

Enter up to 16 characters

See field *161 for explanation of entries. If fewer than 16 characters, exit by pressing [*] and next field number. To clear entries, press *167*.

***168 Pager 3 Report Options**

See pager 1 reports, field *162, except use zone list 11

***169 Pager 4 Phone No.**

Enter up to 20 digits

If entering fewer than 20 digits, exit by pressing [*] + next field number. To clear entries, press *169*.

***170 Pager 4 Characters**

Enter up to 16 characters

See field *161 for explanation of entries. If fewer than 16 characters, exit by pressing [*] and next field number. To clear entries, press *170*.

***171 Pager 4 Report Options**

See pager 1 reports, field *162, except use zone list 12

***172 Pager Delay Option for Alarms**

0 = none; 2 = 2 minutes; 1 = 1 minute; 3 = 3 minutes

This field determines the delay of alarm reports to the pager. This gives the Central Station enough time to verify the alarm report that it received, before the dialer attempts to dial the pager.

This delay is for ALL pagers in the system

Miscellaneous System Fields

***174 Clean Me Option**

0 = disable; 1 = enable

This is a maintenance feature for ESL 2-wire smoke detectors on Zone 1. If used, this option limits the number of smoke detectors to a maximum of 10, rather than 16. To enable the “clean me” feature, a time response setting of “3” (1.2 seconds) must be entered in *56 Zone Programming for zone 1.

***177 Device Duration 1, 2**

- | | | | |
|-------------|---------------|--------------|---------------|
| 0 = 15 secs | 4 = 90 secs | 8 = 4 min | #+12 = 8 min |
| 1 = 30 secs | 5 = 2 min | 9 = 5 min | #+13 = 10 min |
| 2 = 45 secs | 6 = 2-1/2 min | #+10 = 6 min | #+14 = 12 min |
| 3 = 60 secs | 7 = 3 min | #+11 = 7 min | #+15 = 15 min |

These entries set the duration for output action options 5 (duration 1) and 6 (duration 2) programmed in *80 Output Function Programming.

***181 50/60 Hz AC Operation**

0 = 60 Hz; 1 = 50 Hz

Select the type of AC power applied to the control (option is used for Real-Time Clock synchronization)

Configurable Zone Type Fields

- The system allows you to define up to four custom zone types based on the options described at right.
- All configurable zone types can be programmed via the downloader.
- Configurable zone types 90 and 91 can also be programmed from a keypad using data fields *182-*185.
- **IMPORTANT:** Be careful when selecting combinations of options for configurable zone types. Contradictory options can cause unpredictable results.

UL installations: Do not configure zones as fire alarm or UL burglar alarm zones.

*182 Configurable Zone Type 90

0-15 = values for each of 10 entries (0-9, # + 10 = 10, # + 11 = 11, # + 12 = 12, # + 13 = 13, # + 14 = 14, # + 15 = 15)
Enter the appropriate value for each entry, 1-10, based on the charts on the next page. To calculate the value for each entry, add the values of the selected options in each of the entry's columns shown in the respective chart (one option per column). For example, to program entry 2 for "alarm response to short," "auto restore on," but not a "vent zone," enter 5 ("1" for alarm short + "4" for auto restore-yes + "0" for vent zone-no).

*183 Zone Type 90 Report Codes

90 ALARM ID: XXX TROUBLE ID: XXX

Enter the desired 3-digit Contact ID® report codes for alarms and troubles occurring on zones assigned to this zone type. Use existing Contact ID® codes, if appropriate, or define unique codes in CID code range 750-789. Press [*] to accept and continue.

NOTE: Zone alarm report codes (prompt in *56 Menu mode) and trouble report code (*60) and relevant restore codes (*70, *71) must be enabled in order for the configurable zone type codes to be reported.

Important Notice on Report Codes: To avoid confusion at the central station, it is recommended that existing Contact ID® codes be used with configurable zone types whenever possible. See list in **System Communication** section and/or check with the central station for a complete list of Contact ID® report codes. If none of the codes are suitable, choose a code in the reserved range of 750-789 and make sure to define the code with your central station.

*184 Configurable Zone Type 91

0-15 = values for each of 10 entries (see field *182 for explanation of entries.)

*185 Zone Type 91 Report Codes

91 ALARM ID: XXX TROUBLE ID: XXX

See field *183 for explanation of entries and read the Important notice on using these codes.

Configurable Zone Type Options

Auto Restore (entry 2): Faults on zones set for this option are cleared; restore messages sent upon restoral of faults.
Vent Zone (entry 2): Zones set for this option are ignored if faulted when arming the system, but are protected if the zone is later restored (e.g., an open window can be ignored when arming, but if the window is later closed, it will be protected; opening the window again causes an alarm.)
Bypass Disarmed (entry 4): Zones set for this option can be bypassed only while the system is disarmed.
Bypass Armed (entry 4): Zones set for this option can be bypassed when the system is armed.
Dial Delay (entry 6): Alarms on zones set for this option participate in dial delay central station reporting, if system dial delay enabled in field *50.
Fault Delay (entry 6): Faults on zones set for this option are delayed by the time set in field *87. Do not use this option if using entry/exit delay for this zone type.
Faults Display (entry 7): Selects how faults on zones set for this zone type are displayed.
Power Reset/Verification (entry 7): Selects whether the system resets power (when user enters code + OFF), and whether the system performs alarm verification (see description for zone type 16 in Zone Type Definitions section) when a fault occurs on these zones.
Use Entry Delay (entry 8): Selects whether to use the system's entry delay times.
Use Exit Delay (entry 8): Selects whether to use the system's exit delay time.
Interior Type (entry 8): Zones set for this option are treated same as standard zone type 4 (bypasses when armed STAY, faults displayed).
Alarm Sounds (entry 9): Selects the type of alarms sound for zones set for this zone type.
Bell Timeout (entry 9): Alarm sounding on zones set for this option remain for the duration set in fields *32 / *33.
Fire Zone (entry 9): Zones set for this option respond in the same manner as if programmed for zone type 9. Do not set fire zones to respond as a "fault" in entries 1-6.
Trouble Sounds (entry 10): Selects the type of trouble sounds for zones set for this zone type (periodic beeps = once every 30 seconds; trouble beeps = rapid beeping).
Chime Enable (entry 10): Zones set for this option cause a chime when Chime mode is on.

Configurable Zone Type Charts

ENTRY 1		ENTRY 2		
Response when system disarmed and zone is:				
Intact EOL RF zone normal	Open RF zone N/A	Shorted RF zn off-normal	Auto Restore	Vent Zone
0 = normal 1 = alarm 2 = trouble 3 = fault	0 = normal 4 = alarm 8 = trouble 12 = fault see note 5	0 = normal 1 = alarm 2 = trouble 3 = fault see note 6	0 = no 4 = yes	0 = no 8 = yes
Entry 1 = EOL + Open		Entry 2 = Short + auto restore + vent zone		

ENTRY 3		ENTRY 4		
Response when armed STAY and zone is:				
Intact EOL RF zone normal	Open RF zone N/A	Shorted RF zn off-normal	Byp. when disarmed	Byp. when armed
0 = normal 1 = alarm 2 = trouble 3 = fault	0 = normal 4 = alarm 8 = trouble 12 = fault see note 5	0 = normal 1 = alarm 2 = trouble 3 = fault see note 6	0 = no 4 = yes	0 = no 8 = yes
Entry 3 = EOL + Open		Entry 4 = Short + byp. disarmed + byp. armed		

ENTRY 5		ENTRY 6		
Response when armed AWAY and zone is:				
Intact EOL RF zone normal	Open RF zone N/A	Shorted RF zn off-normal	Dial Delay (see field *50)	Fault Delay (see field *87)
0 = normal 1 = alarm 2 = trouble 3 = fault	0 = normal 4 = alarm 8 = trouble 12 = fault see note 5	0 = normal 1 = alarm 2 = trouble 3 = fault see note 6	0 = no 4 = use delay	0 = no 8 = use delay see note 1
Entry 5 = EOL + Open		Entry 6 = Short + dial delay + fault delay		

ENTRY 7		ENTRY 8		
Display Faults	Power Reset/ Verification	Use Entry Delay 1/2	Use Exit Delay	Respond as Interior Type
0 = show alarms when armed & disarmed 1 = don't show alarms when armed (show alarms, trbles, faults when disarmed) 3 = never show any alarms, trbles, faults	0 = no 4 = power reset after fault (with code + OFF) 12 = verification (see zone type 16)	0 = no 1 = delay 1 2 = delay 2	0 = no 4 = use exit delay	0 = no 8 = yes see note 2
Entry 7 = fault display + power reset/verification		Entry 8 = entry delay 1/entry delay 2 + exit delay + interior zone type		

ENTRY 9			ENTRY 10	
Alarm Sounds	Use Bell Timeout	Respond as Fire Zone	Trouble Sounds	Chime when Chime Mode On
0 = none 1 = steady keypad 2 = steady bell and keypad 3 = pulsing bell and keypad	0 = no 4 = yes see fields *32, *33	0 = no 8 = yes see zone type 09; see note 4	0 = none 1 = periodic beep 2 = trouble beeps	0 = no 4 = yes
Entry 9 = alarm sounds + bell timeout + fire zone			Entry 10 = trouble sounds + chime	

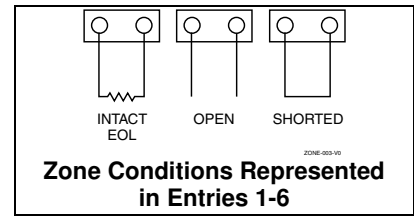

Configurable Zone Type Notes

- Do not use the “fault delay” option with a configurable zone type if it is set for an entry or exit delay, otherwise unpredictable results may occur.
- To create an interior type zone, select “respond as interior zone type” (entry 8, interior type = yes), and set zone response to “fault” in entries 3-4 to ensure fault displays; do not set as “normal,” “alarm,” or “trouble.”
- Do not set fire zones to respond as a “fault” (entries 1-6), otherwise faults will not display unless the [*] key is pressed.
- 4219/4229 modules must use EOLRs or unpredictable results may occur.
- RF Zones: The “open” options in entries 1, 3, and 5 are not applicable for RF zones. Use the “intact EOL” option for normal RF zone conditions and “shorted” for off-normal RF zone conditions.
- a. Zone-Doubling/Double-Balanced: A short on either zone of a zone-doubled pair or on a double-balanced zone causes a tamper condition.
b. For double-balanced zones, this entry must be “0”.
c. For zone-doubled zones, **both** zones of the doubled pair must be assigned the same response to a short.

Touch Screen Keypad (AUI) Enable

The system supports up to four touch screen style keypads (e.g., Symphony Advanced User Interface (AUI), and 6270 Touch Screen keypad).

NOTE: Use of touch screen devices does not affect the number of standard keypads supported.

***189 AUI Device 1 - 4 Enable** (for TouchScreen Style Keypads)

For Touchscreen device usage

- 0 = disable
- 1 = partition 1
- 2 = partition 2
- 3 = partition 3 (common)

For Remote Services device usage

- 5 = part. 1 (auto-stay arm disabled)
- 6 = part. 2 (auto-stay arm disabled)
- 7 = part. 3 (common; auto-stay arm disabled)

Device Addresses:

Set AUI addresses as follows:

- AUI 1 address = 1
- AUI 2 address = 2
- AUI 3 address = 5
- AUI 4 address = 6

AUI Compatibility Note: To ensure proper AUI device operation, use AUI devices with the following rev levels: 6270 series use version 1.0.9 or higher; 8132/8142 (Symphony) series use version 1.1.175 or higher.

To enable a touchscreen keypad, enter the option corresponding to each touchscreen's home partition.

Note for Remote Services Devices: If using the Remote Services feature of the communication device, select an option 5-7, depending on the partition the Remote Services device is associated with (these options automatically disable auto-stay arming when the system is armed from the respective Remote Services device). Refer to the communication device's installation instructions for details on enabling the Remote Services feature.

NOTE: If using Remote Services (IP/GSM feature), one of the touch screen (AUI) addresses may be used for enhanced Remote Services feature set, though a physical touch screen is not installed. See *29 Menu Mode section for enabling Remote Services.

Remote Services Device Address: Using an AUI device address for Remote Services provides enhanced remote services features, but an actual AUI device cannot use the same address. If no AUI addresses are available (all four AUIs are being used), Total Connect 2 cannot be used for remote services. However, Total Connect 1 can be used by choosing an available standard keypad address and using the appropriate keypad address field *190 - *196 to select the Remote Services operating partition (some remote access features will be unavailable).

Keypad Programming Fields

To enable keypads:

1. Set desired address at keypad (refer to keypad's instructions for setting the address).
2. Use data field program mode to enable keypad addresses, assign a partition, enable sound options in fields *190-*196 as shown in the table above.
3. If desired, use data field *198 to turn on the display of the partition number.
4. Set the following keypad-related data fields as required by the installation:
*21 Quick Arm Enable, *23 Forced Bypass, *84 Auto STAY Arm
5. If using touch screen devices (AUI), enable each unit in field *189 and set appropriate AUI addresses.

NOTES:

1. Options for keypad 1, address 16 are set by the factory and cannot be changed.
2. Each keypad must be assigned a unique address, **starting at address 16** (address 16 is reserved for keypad 1, which is automatically set to partition 1 with all sounds enabled). Keypads programmed with the same address will give unpredictable results.
3. If using Remote Services (IP/GSM feature), one of the keypad addresses may be used for limited Remote Services features, though a physical keypad is not installed. See *29 Menu Mode section for enabling Remote Services.

***190 Keypad 2 Device Address 17**

Entry 1 – Partition Assignment:

For Touchscreen device usage

- 0 = disable
- 1 = partition 1
- 2 = part. 2
- 3 = part. 3 (common)

For Remote Services device usage

- 5 = part. 1 (auto-stay arm disabled)
- 6 = part. 2 (auto-stay arm disabled)
- 7 = part. 3 (common; auto-stay arm disabled)

Entry 2 – Sound Option:

- 0 = no suppression
- 1 = suppress arm/disarm and E/E/ beeps
- 2 = suppress chime beeps only
- 3 = suppress arm/disarm, E/E/ beeps and chime beeps

Entry 1: Enter the partition in which the keypad is located.

Entry 2: Enter the desired sound option for this keypad

Note for Remote Services Devices: If using the Remote Services feature of the communication device, select an option 5-7, depending on the partition the Remote Services device is associated with (these options automatically disable auto-stay arming when the system is armed from the respective Remote Services device). Refer to the communication device's installation instructions for details on enabling the Remote Services feature.

***191 Keypad 3 Device Address 18**
See field *190 for entries and explanation.

***192 Keypad 4 Device Address 19**
See field *190 for entries and explanation.

***193 Keypad 5 Device Address 20**
See field *190 for entries and explanation.

***194 Keypad 6 Device Address 21**
See field *190 for entries and explanation.

***195 Keypad 7 Device Address 22**
See field *190 for entries and explanation.

***196 Keypad 8 Device Address 23**
See field *190 for entries and explanation.

***197 Exit Time Display Interval**
0 = no display; 1-5 = seconds between display updates
If enabled, keypads display the exit time remaining after arming the system, updated at the interval selected (i.e. if the exit delay is 30 seconds and “2” is selected in this field, the keypad display refreshes every 2 seconds, displaying 30, 28, 26, 24, etc.).
An interval greater than “1” may be necessary for some older keypads to allow users time to enter key presses between display updates.

TOUCH SCREEN DEVICE NOTE: If using more than one touch screen device (e.g., 6270, Symphony) with the system, leave field *197 Exit Time Display Interval set to the default value “0.” The 6270 automatically displays remaining exit time in one-second increments.

FIXED-WORD KEYPAD NOTE: If using 2-digit display keypads (e.g. 6150RF), do not use exit times greater than the 96-second delay option. Using a longer delay time may cause end-user confusion because 2-digit display keypads cannot display times greater than “99.” If longer exit time is required by the installation, it is recommended that the Exit Time Display option be disabled (“0”).

***198 Display Partition Number**
0 = no; 1 = yes
If selected, the partition number is displayed in the upper-left corner of the display. This is useful when using the GOTO partition function.

***199 ECP Fail Display**
0 = 3-digit display (“1” + device address)
1 = 2-digit fixed-display as “91”
Select “0” if using Alpha keypads and/or 3-digit Fixed-Word Display keypads. ECP faults will display “1” plus the device address (00-15) of device causing the fault (e.g., faults on device 07 display as “107”).
Select “1” if using 2-digit Fixed-Word Display keypads (e.g., certain 6128 series keypads). If selected, ECP faults for all devices will display as “91” on 2-digit displays, and “191” on 3-digit or Alpha keypads.

Menu Mode Programming

Zones and Partitions

Each protection zone needs to be programmed with various attributes using *56 Zone Programming mode or *58 Expert Programming Mode.

The system can control two independent areas of protection (known as partitions) for use by independent users, if desired, by simply assigning zones to one or the other partition during zone programming. The system, by default, automatically distributes users between the two partitions. The master user can change the user number distributions.

Zones can also be assigned to a common partition, which is an area shared by users of both partitions (such as a lobby in a building). This allows either partition to arm, while leaving the common partition disarmed for access into the other partition. The following describes the functioning of the common partition:

- The common zone sounds and reports alarms only when both partitions are armed. If only one partition is armed, the system ignores faults on the common zone.
- Either partition may arm its system if the common zone is faulted, but once armed, the other partition will not be able to arm unless the common zone is first bypassed or the fault is corrected.
- Faults on the common zone are displayed on common zone keypads, and will also appear on another partition's keypad when that partition is armed.
- Either partition can clear and restore the common zone after an alarm.

About Zone Programming (*56 and *58 Menu Modes)

- Used to program zones, zone types, report codes, enroll 5800 RF Wireless Transmitter serial numbers, and identify the type of loop input device(s).
- Can also be used to enter alpha descriptors for programmed zones; however, we recommend entering descriptors in menu mode *82 (*Alpha Descriptor Programming* after all zone programming has been completed).
- *58 Expert Programming mode provides a faster method of zone programming than *56 Menu mode, but is recommended only for those who have had previous experience in programming controls of this type.

NOTE: Alpha display prompts are shown in a double-line box.

*56 Zone Programming Procedure

1. Enter the zone number to be programmed.
2. Make appropriate entries at the prompts.
3. Confirm the serial number of wireless transmitter zones.

Start Zone Programming mode by pressing *56 while in Data Programming mode.

SET TO CONFIRM? 0 = NO 1 = YES

Set to Confirm

0 = no; 1 = yes

If 1 (Yes) is entered, you will be prompted to confirm each transmitter after entering the serial and loop numbers (at the "XMIT TO CONFIRM" prompt later in this procedure). **We recommend that you confirm the programming of every transmitter.**

Enter Zn Num.
(00 = Quit) 10

Zone Number

wired 01-08 (and 09-48†); wireless 09-48; RF button zones 49-64
91 = addr. device report enable; 92 = duress report enable; 95, 96, 99 =emerg. zones
[*] to continue; 00 to quit † if zone expanders are used.

Enter the zone number that you wish to program. Zone 10 has been entered in the example display at left.

Enter a report code for zone 91 to enable addressable device reporting.

Enter a report code for zone 92 to enable duress reporting.

95, 96, 99 are emergency (panic) key zones.

Zn ZT P RC In: L
10 00 1 10 RF: 1

Summary Screen

[*] to continue

A summary display appears.

“IN: L” appears for wireless zones and indicates input type and loop.

“IN: AD” appears for hardwire expansion zones (AW) and indicates the module’s address (AD), which is based on the zone number.

“HW: RT” appears for hardwire zones and indicates configuration (EOL, NO, NC, zone doubling, double-balanced) and response time selection.

OR

Zn ZT P RC In: AD
10 00 1 10 AW: 07

OR

Zn ZT P RC HW: RT
10 00 1 10 EL 1

10 Zone Type
Perimeter 03

Zone Type (ZT)

See table below.

Each zone must be assigned to a zone type, which defines the way in which the system responds to faults in that zone. Enter the Zone Type code from the list below:

Note: If 00 is entered, **Delete Zone ?** will be displayed.

- | | | |
|------------------------|------------------------|----------------------|
| 00 = Not used | 07 = 24-Hr Audible | 20 = Arm-STAY* |
| 01 = Entry/exit #1 | 08 = 24-Hr Aux | 21 = Arm-AWAY* |
| 02 = Entry/exit #2 | 09 = Fire | 22 = Disarm* |
| 03 = Perimeter | 10 = Interior w/Delay | 23 = No Alarm Resp |
| 04 = Interior Follower | 12 = Monitor Zone | 24 = Silent Burglary |
| 05 = Day/Night | 14 = Carbon Monoxide** | 77 = Keyswitch |
| 06 = 24-Hr Silent | 16 = Fire w/Verify | 81 = AAV Mon. Zone |
| | | 90-91 = Configurable |

*5800 button-type transmitters only

** For wireless zones set for zone type 14, use only compatible wireless carbon monoxide detectors (ex. 5800C0)

10 Partition
1

Partition No. (P)

1-3 = partition (3 = common); [*] to continue

Enter the Partition number for this zone. Partition 1 is shown entered.

10 Report Code
1st 01 2nd 00 10

Report Code (RC)

First Digit: 1-9, 10 for 0, 11 for B, 12 for C, 13 for D, 14 for E, 15 for F
00 to disable

Second Digit: same as above; [*] to continue

Enter the report code for this zone, which consists of 2 hexadecimal digits, each in turn consisting of 2 numerical digits. For example, for a report code of “10,” enter 01 and 00.

For Contact ID®, entering any non-zero entry as the first digit enables the report code for this zone. Refer to the **System Communication** section for information about report codes and formats.

02 HARDWIRE TYPE
EOL 0

Hardwire Type

0 = EOL; 1 = NC; 2 = NO; 3 = zn doubling (ZD); 4 = dble-balanced (DB)

[*] to continue

This prompt appears only for zone numbers 02-08.

Zone 1 is automatically set for EOL operation.

02 Response Time
1

Response Time (RT)

0 = 10mSec; 1 = 350mSec; 2 = 700mSec; 3 = 1.2 seconds; [*] to continue

This prompt appears only for hard-wired zones 01-08 (zone 02 is the display shown).

Option 3: used for “clean me” option on zone 1 (see field *174).

NOTE: If zone doubling is being used, the response time selected for zones 02-08 automatically applies to each zone’s associated doubled zone.

10 INPUT TYPE	L
RF TRANS	3

Input Device Type (In)

2 = AW (Aux wired zone)

3 = RF (supervised RF transmitter)

4 = UR (unsupervised RF transmitter)

5 = Button type RF transmitter (unsupervised).

[*] to continue

This prompt is skipped for zones 2-8, or 2-16 if zone-doubling was enabled at “Hardwire Type” prompt.

All of the RF transmitters have one or more unique factory-assigned input (loop) ID codes. Each of the inputs requires its own programming zone (e.g., a 5804's four inputs require four programming zones).

RF Transmitters can be enrolled as one of the following types:

Type	Description
RF (Supervised RF)	Sends periodic check-in signals, as well as fault, restore, and low-battery signals. The trans. must stay within receiver's range.
UR (Unsupervised RF)	Sends all the signals that the “RF” type does, but the control does not supervise the check-in signals. The transmitter may therefore be carried off-premises.
BR (Unsupervised Button RF)	Sends only fault signals. It will not send a low-battery signal until it is activated. The transmitter may be carried off-premises.

NOTE:

- For the built-in hardwired zones, the Input Device type is automatically displayed as HW and cannot be edited.
- To change the input type of a previously programmed wireless device (type RF, UR, BR) to a wired zone (type AW), you must first delete transmitter's serial number (see To Delete A Serial Number prompt on next page)

10 INPUT S/N:	L
A022-4064	1

Serial number Entry and Loop Number Entry

[*] to continue

Used only when enrolling wireless transmitters.

- Transmit two open/close sequences. If using a button-type transmitter, press and release the button twice, but wait about 4 seconds before pressing the button the second time.

OR

- Manually enter the 7-digit serial number printed on the label of the transmitter. Then press the [*] key – the cursor will move to the “L” position. You can edit the loop number, if necessary. When the loop number is acceptable, press [*].
- Press key [C] to copy the serial number previously enrolled (used when programming a transmitter with several input loops).

10 INPUT S/N	L
A022-4064	?

Loop Number Change

[*] to continue

NOTE: If the [C] key is used to copy the previously enrolled serial number, the cursor will move to the Loop column (L) with the previous serial number displayed, and display a highlighted question mark for the loop number.

Enter the loop number and press [*]. The system will now check for a duplicate serial/loop number combination.

10 INPUT S/N	L
A022-4064	1

Enroll Summary

[*] to continue

If the serial/loop number combination is not a duplicate in the system, a display showing the serial number and loop number entry will appear.

XMIT TO CONFIRM
PRESS * TO SKIP

Confirmation Option

[*] to continue

This prompt will only appear if you answered “Yes” at the first prompt in this section.

The system will enter a confirmation mode so that the operation of the actual programmed input can be confirmed.

Activate the loop input or button that corresponds to this zone.

Entd A022-4063 1
Rcvd A022-4064 1

If Serial or Loop Numbers do not match after activating the transmitter

[*] to continue

If the serial number transmitted does not match the serial number entered, a display similar to the one shown appears. If the loop number does not match, it will also be displayed.

If so, activate the loop input or button on the transmitter once again. If a match is not obtained (i.e., summary display does not appear), press the [#] key twice and then enter (or transmit) the correct serial number.

10 INPUT S/N: L
A000-0000 0

To Delete a Serial No.

0 in loop number field = delete serial number; # = undo deletion; [*] to continue

To delete an existing serial number, enter 0 in the loop number field. The serial number will change to 0's.

If 0 was entered in error, simply re-enter the loop number or press [#], and the serial number will return to the display.

Zn ZT RC In: L
10 03 10 RF: 1s

Summary Screen

[*] to continue

If the serial number transmitted matches the serial number entered, the keypad will beep 3 times and a summary display will appear, showing that zone's programming. Note that an "s" indicates that a transmitter's serial number has been enrolled.

Press [*] to accept the zone information and continue.

PROGRAM ALPHA?
0 = NO 1 = YES 0

Alpha Descriptors

0 = no; 1 = yes; [*] to continue

If you want to program descriptors for zones now, enter 1 (Yes) and refer to the **Alpha Descriptor Programming** section for available descriptors.

ENTER ZN NUM.
(00 = QUIT) 11

Next Zone Number

[*] to continue; 00 = quit

If 0 (No) was entered above, the system will return you to the ENTER ZN NUM. prompt for the next zone.

When all zones have been programmed, enter 00 to quit.

Completing Zone Programming

- When you have finished programming all zones, test each zone using the system's TEST mode.
- **Do not use the Transmitter ID Sniffer Mode for checking wireless transmitting devices**, as it will only check for transmission of one zone on a particular transmitter, NOT the zones assigned to each additional loop.

NOTE: Following the successful enrollment of each wireless device, note the device serial number in the appropriate column on the ENROLLED TRANSMITTERS worksheet in the Programming Form; then enter the other information (zone number, zone type, loop number, etc.) relevant to that device.

***58 Expert Programming Mode Procedures**

This method is designed for use by installers with previous experience in programming ADEMCO control panels. This mode is also used to program wireless keys using pre-defined templates.

Start Expert Programming mode by pressing *58 while in Data Programming mode.

SET TO CONFIRM?
0 = NO 1 = YES 0

Confirm?

0 = no; 1 = yes; [*] to continue

This display appears upon entry into this mode. The default is 0 (No).

If 1 (Yes) is entered, you will be prompted to confirm each transmitter after entering the serial and loop numbers (at the "XMIT TO CONFIRM" prompt later).

Zn	ZT	P	RC	HW:	RT
01	09	1	10	EL	1

Summary Screen

01-64 = zone number; [*] to continue; 00 = quit

OR [D] to go to prompts for wireless key programming templates

A summary screen appears, showing zone 1's currently programmed values.

Zn	ZT	P	RC	IN:	L
10	00	1	10	:RF	-

Enter the zone number being programmed, then press [*], which displays a summary screen for that zone. See next prompt (zone 10 in this example).

If programming a wireless key, press the [D] key then skip to the Wireless Key Programming Templates section following this section. When [D] is pressed, you can choose from a series of preset templates for easy programming of wireless key zones.

When all zones have been programmed, press 00 at this prompt to quit this menu mode.

Zn	ZT	P	RC	IN:	L
10	00	1	10	RF	1

Zone Programming

ZT = see Zone Type chart shown in *56 Menu Mode "Zone Type" prompt

P = partition 1, 2, 3 (common); RC = 1 (send CID report); 0 (no report)

IN = input type; L = loop number

[*] to continue

A summary screen with the selected zone's current programming appears.

Begin programming zone information as follows:

- Enter Zone Type (ZT), Partition (P), Report Code (RC; 0-9 only; use *56 mode to enter hex codes), and Input Device Type (IN)* sequentially, but not the Loop No. (L).
- Use the [A] (Advance) and [B] (Back) keys on the keypad to move the cursor within the screen.
- Use the [C] key to copy the previous zone's attributes.

Press [*] to save the programming and continue to the serial number/loop number prompt.

If needed, you can press the [#] key to back up without saving.

* If HW (hardwired) or AW (Auxiliary) is entered for Input Device Type, the next screen will be similar to the prompt shown, except that HW or AW will be displayed under "IN". If RF, BR, or UR is entered, a prompt for Serial and Loop number will be displayed, as follows.

10	INPUT S/N:	L
	AXXX-XXX	-

Serial number

S/N = serial number; L = loop number; [*] to continue

Manually enter the serial number (found on the transmitter label), by typing digits in the "X" locations, using the [A] (advance) or [B] (back) keys as required. You can also perform two open and close sequences; for button-type transmitters that means pressing and releasing the button twice.

NOTE: If you want to copy the previous zone's serial number, press the [C] key.

Press [*] to advance to the loop number, then enter loop number.

Press [*] to accept the existing serial and loop number and continue to the "Confirm" prompt below. If necessary, press [#] to back up and re-enter or edit the serial number.

10	INPUT S/N:	L
	A000-0000	0

To Delete a Serial Number

[*] to continue

To delete an existing serial number, enter 0 in the loop number field. The serial number will change to all 0's as shown.

If 0 was entered in error, simply re-enter the loop number, and the serial number will return to the display.

10	XMIT TO CONFIRM
	PRESS * TO SKIP

Confirm

[*] to continue

The prompt to confirm appears. This prompt will only appear if the first prompt after entering *58 was answered "Yes." To confirm, activate the loop input or button that corresponds to this zone.

The system checks for duplicate. If a duplicate exists, a long error beep will sound.

Press [#] to back up and re-enter the serial and/or loop number.

Entd	A022-4063
Rcvd	A022-4064

If Serial or Loop Numbers do not match after activating the transmitter

[*] to continue

If the serial/loop number combination transmitted does not match the serial and loop number entered, a display similar to the one below will appear. **If the loop number does not match, it will also be displayed.** If so, activate the transmitter’s loop input or button one or more times.

If a match is still not obtained (i.e., summary display does not appear), press the [#] key twice and enter the correct loop input or, if correct, press [#] again and then enter the correct serial number.

Zn	ZTP	RC	In	L
10	03	1	10	RF:1s

Note that an “s” indicates that a transmitter’s serial number has been enrolled.

Summary Screen

If the serial number transmitted matches the serial number entered, the keypad will beep 3 times and a summary display will appear, showing the programmed information for that zone.

Press [*] to begin programming the next zone. See first “Summary Screen” prompt paragraph on previous page.

To exit this mode, enter 00 at the Summary Screen prompt.

Wireless Key (Key Fob) Programming & Templates

This procedure programs the wireless keys, **but a key is not active for arming/disarming until it is assigned to a user number** (see *System Operation* section, assigning attributes command).

To program a wireless key, do the following:

1. Use Zone programming mode to manually program a zone for each button being used on the wireless key.
OR, use the Template program mode described below to automatically program each button (loop) to a zone type based on the selected wireless key template number. Wireless key zone numbers range from zone 49-64.
2. Enroll the wireless key serial number into the system.
3. Assign the wireless key to a user number if it is intended to arm/disarm the system. Refer to the assigning attributes command in the *System Operation* section of the Installation Instructions manual.

Programming Wireless Key Templates

Enter this mode by pressing the D key while at the *58 Menu mode Summary Screen. The following prompts appear.

TEMPLATE ?	
1-6	1

Template Number

1-3 = 5804 templates; 4-6 = 5804BD templates

- Enter Template number 1-6 (see chart on next page). See the defaults provided for each template in the chart that follows these procedures.
- Select from templates. Press [*] to display template (1 shown selected).
NOTE: If necessary, press [#] to back up and re-enter template number.
- Press [#] if you want to return to *58 Menu mode summary screen.

L	01	02	03	04
T	23	22	21	23

Template Display

- When [*] is pressed, the selected template will be displayed.
Top line of display represents loop numbers; bottom line represents zone type assigned for each loop.
- Press [*] to accept template.

PARTITION	
	1

Partition

1 = partition 1; 2 = partition 2

- Enter the partition in which the key is to be active, then press [*] to continue.

ENTER START ZONE	
00 = QUIT	36

Start Zone Number

- The system will search for the highest available consecutive 4-zone group (the four zones in the case of the 5804 and 5804BD), and display the lowest zone number of the group. If you want to start at a different zone, enter the zone desired, and press [*]. If that zone number is displayed, the system has the required number of consecutive zones available, beginning with the zone you entered. If not, the system will again display a suggested zone that can be used.
If the required number of consecutive zones is not available at all, the system will display “00”.

To quit this mode and return to *58 Menu mode, enter 00 at this prompt.

- Press [*] to accept.

INPUT S/N	L
AXXX-XXXX	-

Serial Number

- Manually enter the serial number printed on the label for the wireless key or press and release the button to transmit its serial number.
- Press [*] to accept the serial number. The system will check for a duplicate.
- If necessary, press the [#] key to back up without saving, and re-enter the serial number.
- Use the [A] key to move forward within the screen, and the [B] key to move backward.

XMIT TO CONFIRM
PRESS * TO SKIP

Confirm

[*] to continue

- If “Yes” was entered at the **SET TO CONFIRM?** prompt previously (see first prompt following entry into the *58 Expert Programming Mode), the display on the left will appear. Confirm serial and loop numbers by activating the wireless key.

IMPORTANT:

When confirmed, the key is not active for arming/disarming until it is assigned to a user number (using the assigning attributes command, attribute “4”). See **System Operation** section for procedure.

Entd A022-4063
Rcvd A022-4064

Not Confirmed

[*] to continue

If the serial number transmitted does not match the serial number entered, a display similar to the one shown will appear. If the loop number does not match, it will also be displayed.

If so, activate the button on the wireless key once again. If a match is not obtained (i.e., summary display does not appear), press the [#] key and then enter the correct serial number.

If the serial number transmitted matches the serial number entered, the keypad will beep 3 times and will return you to the Zone Number prompt to enter the starting zone for the next wireless key.

Or you can return to *58 Menu mode by pressing 00 at the Zone Number prompt.

NOTE: Following the successful enrollment of each wireless device, remove **ONE** of the serial number labels from the device and affix it in the appropriate column on the ZONE PROGRAMMING worksheet of the Programming Form; then enter the other information (zone number, zone type, loop number, etc.) relevant to that device.

Wireless Key Predefined Default Templates

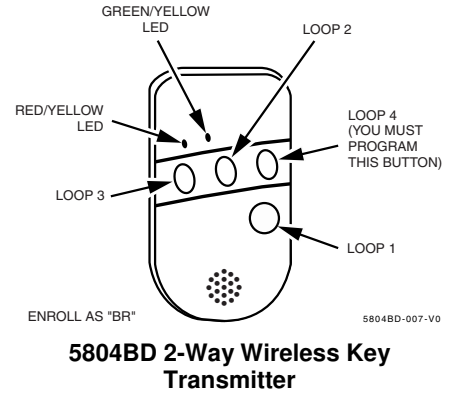
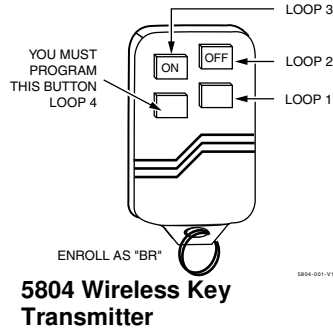
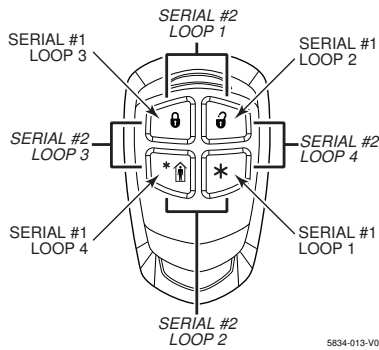

5834-4 Wireless Key Transmitter

NOTE: Some transmitters are not intended for use in UL installations.

TEMPLATE 1	For button Type Devices			TEMPLATE 4	For Button Type Devices		
	Loop	Function	Zone Type		Loop	Function	Zone Type
	1	No Response	23		1	No Response	23
	2	Disarm	22		2	No Response	23
	3	Arm Away	21		3	Arm Away	21
	4	No Response	23		4	Disarm	22
TEMPLATE 2	Loop	Function	Zone Type	TEMPLATE 5	Loop	Function	Zone Type
	1	No Response	23		1	No Response	23
	2	Disarm	22		2	Arm Stay	20
	3	Arm Away	21		3	Arm Away	21
	4	Arm Stay	20		4	Disarm	22
TEMPLATE 3	Loop	Function	Zone Type	TEMPLATE 6	Loop	Function	Zone Type
	1	24-hour audible	7		1	24-hour audible	7
	2	Disarm	22		2	Arm Stay	20
	3	Arm Away	21		3	Arm Away	21
	4	Arm Stay	20		4	Disarm	22

About Output Device Programming (*79/*80 Menu Mode)

Output Devices: The system supports up to 16 relays and/or Powerline Carrier devices (X-10 devices) plus 2 built-in trigger outputs in any combination. These 18 “outputs” are assigned to system-wide output numbers (01-18). Use *79 Menu Mode to assign output numbers and map them to device addresses.

Output Functions: The system also provides installer-defined output functions, which can be assigned to any of the physical outputs. Therefore, the action of any one of the outputs can be based on as many of these functions as desired. This lets a single relay or X-10 device perform many functions.
The controls support up to 48 output functions.
Use *80 Menu Mode to define output functions.



Relays and output devices are not recommended for life safety applications.

NOTE: When navigating the *79 and *80 menus: The [*] key is used to accept an entry and advance to the next prompt. The [#] key is used to revert back to the last question to check or change an entry. Press [*] to go forward again.

Programming Output Devices

1. Use *79 Menu Mode to assign module and output numbers and map them to device addresses.
NOTE: You must map output devices using *79 Menu Mode **before** you can use *80 menu Mode.
2. Use *80 Menu Mode to create output definitions, which control the output devices, if desired.
3. Use *81 Zone List Menu mode to define zone lists for use with output devices if the device action is based on more than one zone.
 - To program a device for manual activation (user code + [#] [7] / [#] [8] + 2-digit device number) or for scheduled automatic activation, simply map the device using *79 Menu mode.
 - To program a device to automatically activate upon a system event (or function key), use *79 Menu mode to map the device, then use *80 Menu mode to define the automated device action.

*79 Menu Mode: Output Device Mapping

Use this menu to assign Relay Module device addresses and specific relay numbers, and Powerline Carrier unit numbers. The system is based on predefined module addresses for 4204 and 4229 modules. Refer to the table shown at the “Module Address” prompt on the next page and set the modules’ addresses (via module DIP switches) accordingly.

The following table shows how these outputs are identified.

Output Identification

This output...	is identified by...
Relays	the Relay Module’s device address and the relay position on that module (i.e. the physical relay number, 1-4, on that module).
X-10 Device	a house ID (entered in data field *27) and the unit number of the device.
Built-in Outputs	the output number assigned, 17 for Trigger 1 and/or 18 for Trigger 2.

Start Output Device Mapping by pressing *79 while in Data Programming Mode.

***79 Output Device Menu Mode**

ENTER OUTPUT NO. 00 = QUIT xx

Device Output Number

01-18 = relays/X-10

[*] to continue; 00 to quit

This is the logical (or reference) relay number as used in the system. Relays and X-10 devices are numbered 01-16; the on-board triggers are numbered 17 and 18 and can be programmed for inverted output, if required.

17 OUT NORM LOW 0 = NO 1 = YES 0
--

Output Normally Low (prompt appears only for Triggers 17 and 18)

0 = no (standard default); 1 = yes

[*] to continue

Selecting 0 (no) sets the output level normally high (default setting).

Selecting 1 (yes) sets the output normally low.

Output Trigger 17 can be used for resetting 4-wire smoke detectors† by connecting it to the negative power terminal of the smoke detector, selecting 1 at this prompt, and setting as zone type 54, fire zone reset, in *80 Menu mode.

After entry, display returns to Output Number prompt. Use *80 Menu mode to program the function of the trigger.

† **Power Reset:** This control does not automatically reset power to 4-wire smoke detector zones, so you must use a relay (e.g., 4204, 4229) or on-board trigger to reset power (also required for fire verification).

XX OUTPUT TYPE DELETE 0

Output Type

0 = delete; 1 = relay on 4204/4229 module; 2 = Powerline Carrier device (X-10)

[*] to continue

Select whether this is a relay or a Powerline Carrier (X-10) device.

If Powerline Carrier is selected, go to “A” prompt.

If relay is selected, skip to “B” prompt.

“A”

XX UNIT No. yy

Unit Number (prompt appears if X-10 is selected)

01-16 = predefined address

[*] to continue

Enter the unit code (set at the device) and press [*].

The system returns to the Output Number prompt.

“B”

XX MODULE ADDR 07-15 yy

Module Address (prompt appears if relay is selected)

07-15 = predefined address

[*] to continue

Enter the predefined address for this module as listed below. Make sure the module’s DIP switches are set to the selected address.

NOTE: If using Multi-Mode (IP/GSM feature), select one of the 4204 addresses, though a physical 4204 module is not installed. If using 2-4204 multi-mode option, the second 4204 address is automatically one number higher than the first one selected. Make sure these addresses are not used by physical 4204 modules that may be installed. If using Multi-Mode Enhanced Reports option, RIS must be enabled in field *91; when enabled, address 25 is automatically assigned. See *29 Menu Mode section for enabling Multi-Mode.

Module Addresses

Address	Module
07	1st 4229 (with zones 09-16)
08	2nd 4229 (with zones 17-24)
09	3rd 4229 (with zones 25-32)
10	4th 4229 (with zones 33-40)
11	5th 4229 (with zones 41-48)
12	1st 4204
13	2nd 4204
14	3rd 4204
15	4th 4204

XX REL POSITION
1-4 zz

Relay Position

1-4 = relay position

[*] to continue

This is the actual (or physical) relay number with respect to the Relay Module upon which it is located. For 4204 modules, relay numbers are 1-4. For 4229 modules, relay numbers are 1-2.

The system returns to the Output Number prompt for programming the next device.

NOTE: If using multi-mode, program the relays to trigger on those system events to be sent to the user's email address. (4204 option = up to 4 events; 2-4204 option = up to 8 events)

See *29 Menu Mode section for enabling Multi-Mode.

***80 Menu Mode: Defining Output Functions**

Use this mode to program output function definitions (up to 48 functions) that provide automated control of any of the output devices, based on events occurring on individual zones or zones with certain zone types. Each output definition is identified by an output function number, and includes the following components:

Output Definition Components

Component	Description
Output Function No.	A reference number that defines an output's characteristics.
Activated By	Determines whether the initiating event occurs on a zone, a zone list, or a zone type.
Event	Event that triggers the output action. Can be an event occurring on a specific zone number or a zone list, or a specific zone type.
Partition	If the output is activated by zone type, this defines the partition in which the programmed event is to cause the device action.
Output Action	Defines the action of the relay/X-10 device when the defined event occurs. Can close for 2 seconds, stay closed until reset, continuously pulse (1-second close-open-close-open, etc.), toggle the device state, or activate for a defined duration (set in data field *177).
Output No.	Assigns this function to a specific output number (defined in *79 Menu Mode). This is the output number that will perform this function upon the triggering event. Note that each defined function is associated with only one output number. This means that if more than one output device needs to perform this particular function, you need to define another output function number with the same attributes, but assign the appropriate output number. (i.e. output devices can be assigned more than one function number, but each function number can only be assigned a single output number.

For example, if you want to pulse a strobe light upon fire alarms on zone 4 using a relay mapped to output number 2 (as programmed in *79 Menu Mode), program the following in *80 Menu Mode:

Prompt	Entry
Output Funct. # =	01 (assuming this is the first output function)
Activated By: =	3 (zone number)
Enter Zn No. =	04 (requires 2-digit zone numbers)
Output Action =	3 (continuous pulse)
Output Number =	02 (device mapped in *79 Menu Mode)

Start Output Definition mode by pressing *80 while in Data Programming mode.

***80 Output Function Menu Mode**

Output Funct. #
(00 = Quit) 01

Output Function No.

01-48 = output function number

[*] to continue; 00 to quit

Enter the output function number to be defined (or 00 to exit).

01 A E P Trig
?00 0 0 - ZL=00

Summary Screen

[*] to continue

This screen displays a summary of the current output programming (for this example, Zone List has been selected-this is the default screen).

A = Output Action; **E** = Triggering event; **P** = Partition; **Trig** = Trigger type

NOTE: A question mark in the summary screen indicates that the device number shown has not been mapped. Use *79 Menu mode to map the device.

01 Activated By:
Zone List

Activated By

- 0 = delete
- 1 = zone list (go to "A" prompt)
- 2 = zone type (go to "B" prompt)
- 3 = zone number (go to "C" prompt;)
- [*] to continue

Select where the initiating event for this output definition is to occur as follows:

If you enter "0," the following prompt appears:

Delete?
0 = NO, 1 = YES

Press 1 to delete this output definition. The system deletes the output function and any previous programming.

"A"

01 Zn List
1

Zone List (prompt appears if zone list was selected)

01-08 = zone list; [*] to continue

Enter the desired zone list number associated with this output number.

NOTE: Do not use pager zone lists 09-12 in output definitions.

Enter the zone list event that will activate this output.

Enter Event
Alarm 1

0 = restore; 1 = alarm;
2 = fault; 3= trouble

NOTE: For alarm, fault, and trouble, an event on ANY zone in the list activates the output, but ALL zones in the list must be restored before the output is restored.

Press [*] to continue and skip to the "Output Action" prompt.

"B"

01 Enter Zn type
Perimeter 03

Zone Type (prompt appears if zone type was selected)

Enter the desired zone type associated with this output number. See below for a list of available zone types.

CHOICES FOR ZONE TYPES:

- | | | |
|------------------------|-----------------------|--------------------------|
| 00 = Not Used | 05 = Day/Night | 12 = Monitor Zone |
| 01 = Ent/Exit #1 | 06 = 24 Hr Silent | 14 = Carbon Monoxide†† |
| 02 = Ent/Exit #2 | 07 = 24 Hr Audible | 16 = Fire w/verification |
| 03 = Perimeter | 08 = 24 Hr Aux | 23 = No Alarm Response |
| 04 = Interior Follower | 09 = Fire | 24 = Silent Burglary |
| | 10 = Interior w/Delay | 77 = Keyswitch Zone |
| | | 81 = AAV Monitor Zone |
| | | 90-91 = Configurable |

CHOICES FOR SYSTEM OPERATION:

- | | | |
|--------------------------|---------------------------|--------------------------|
| 20 = Arming-Stay | 36 = **At Bell Timeout** | 58 = Duress |
| 21 = Arming-Away | 38 = Chime | 60 = AAV |
| 22 = Disarming | 39 = Any Fire Alarm | 61 = AVS session begin § |
| 31 = End of Exit Time | 40 = Bypassing | 62 = AVS session end § |
| 32 = Start of Entry Time | 41 = **AC Power Failure | 66 = Function Key† |
| 33 = Any Burglary Alarm | 42 = **System Battery Low | 67 = Bell Fail |
| | 43 = Comm. Failure | 68 = Telco Line Cut |
| | 52 = Kissoff | 78 = Keyswitch Red LED |
| | 54 = Fire Zone Reset | 79 = Keyswitch Green LED |

** Use 0 (Any) for Partition No. (P) entry.

*** Or at Disarming, whichever occurs earlier.

† Use *57 Menu Mode to assign the function key (function "07").

†† when used with an output function, the carbon monoxide zone type activates upon CO alarms only. Does not activate for trouble conditions.

§ automatically set when appropriate AVS Quick Command performed.

Note: In normal operation mode:

Code + # + 7 + NN Key Entry **starts** Device NN.

Code + # + 8 + NN Key Entry **stops** Device NN.

Enter the partition in which this zone type will occur.

01 Partition
Any partition 0

0 = any partition; 1 = partition 1;
2 = partition 2; 3 = common

Press [*] to continue and skip to the "Output Action" prompt.

"C"

01 Enter Zn No.	12
-----------------	----

Zone Number (prompt appears if zone number was selected)
 Enter the desired zone number associated with this output number.
 Press [*] to continue.
 Enter the zone event that will activate this output.

01 Enter Event	0
Restore	

0 = restore; 1 = alarm/fault/trouble

Press [*] to continue to the "Output Action" prompt

01 Output Action	
Close for 2 sec	1

Output Action

0 = off
 1 = Close for 2 seconds
 2 = Stay Closed
 3 = Pulse on & off (1 sec ON, 1 sec OFF)
 4 = Change Device State
 5 = Duration 1 (see data field *177)
 6 = Duration 2 (see data field *177)

Enter the desired device action as listed above. Press the [*] key to continue.

Enter Output No.	
R02	02

Output Number

01-16 = output no.; 17-18 = on-board triggers

Enter the device output number (programmed in *79 Menu Mode) you want associated with this output. Press [*] to continue.

02 A E P TRIG	
R02 1 1 3 ZL=00	

Summary Screen

A summary screen appears showing the programmed settings.

Press [*] to continue.

About Zone Lists (*81 Menu Mode)

Zone lists let you group individual zones for use with certain system actions. The following table shows the available zone lists and their purposes:

List No.	Used for...	Notes
1, 2	general purpose (GP)	<ul style="list-style-type: none"> Any list may include any or all of the system's zone numbers. A zone list can be assigned to more than one output relay. Zone List 4: When creating zone list 4 for cross zoning, include only zones assigned to zone types 3, 4, or 5. Do not include zones that have delays (entry/exit zones, interior w/delay) or 24-hour zones, as these zone types may produce unpredictable operation and may not function as intended. See field *85 for Cross Zone Timer option. Zone List 6: V21iPSIA: See field *50 for Dial Delay Disable option. Zone List 7: V21iPSIA: See field *93 for Unlimited Reports option.
3	chime-by-zone (see field *26 to enable option)	
4	cross zones (see note at right)	
5	night stay zones	
6	general purpose V21iPSIA : dial delay disable	
7	general purpose V21iPSIA : unlimited reports	
8	general purpose	
9	zones that activate Pager 1	
10	zones that activate Pager 2	
11	zones that activate Pager 3	
12	zones that activate Pager 4	

Zone List Programming

1. Select an appropriate zone list number.
 2. Add the desired zone numbers to be included in that list.
- Start Zone List Program Mode by pressing ***81** while in Data Programming mode.

*81 Menu Mode

Zone List No. (00 = Quit) 01

Zone List Number

01-12 = zone list number; [] to continue*

Enter the Zone List Number to program (or 00 to quit). Press **[*]** to advance.

In the following displays, zone list 01 has been selected for programming.

01 Enter Zn Num. (00 = Quit) 00

Zone Number

01-64 = zone numbers followed by [] to accept each zone; 00 to continue*

Enter each zone number to add to the zone list, followed by pressing **[*]** (example, 01*, 02*, 03*). After all zones are entered, press 00 to continue.

IMPORTANT: Do not include fire zones in zone lists that are used to STOP device actions.

01 Del Zn List? 0 = No 1 = Yes 0
--

Deleting Zone Lists

0 = don't delete list; 1 = delete this zone list; [] to continue*

To delete the zone list, enter 1. All zones in the zone list will be deleted automatically and the system returns to the Zone List No. prompt.

To save the zone list, enter 0.

01 Delete Zone? 0 = No 1 = Yes 0
--

Deleting a Zone

0 = don't delete zones; 1 = go to next prompt to delete zones; [] to continue*

To save the zone list, enter 0 and the system returns to the Zone List No. prompt.

To delete a zone or zones in a zone list, enter 1 to continue.

01 Zn to Delete? (00 = Quit) 00

Delete the Zone

01-64 = zones to be deleted from list followed by [] to accept each zone; 00 to continue*

Enter each zone to be deleted from the list, followed by **[*]**. After all zones to be deleted are entered, enter 00 to return to the Zone List No. prompt so that another list can be programmed, if desired.

About Function Keys (*57 Menu Mode)

The system provides the ability to program each of the four keypad function keys to perform one of 12 system operations. The end user can then activate the function by simply pressing and holding the programmed key for 2 seconds. Typical functions (listed below) include single-button arming, turning lights on/off, or single-button paging.

To assign emergency key functions (function key option "00"), first program the respective emergency zone number (95 for "A" key, 96 for "C" key, 99 for "B" key) with the desired zone type using *56 Zone Programming mode, then use *57 Function Key menu mode to assign the desired key.

To use a function key to activate a relay action (*57 Menu mode key function 07), use *79 Menu mode to map the output, and use *80 Menu mode to define the output's action; select system operation type "66."

To use a function key for a user macro, use *57 menu mode to activate the desired key, then define the actual macro functions using the user code + [#] + [6] [6] command.

Programming Function Keys

1. Assign the function key number and partition.
2. Select the desired function for that key.

Start Function Key Programming mode by pressing *57 while in Data Programming mode.

Press Key to Pgm 0 = Quit 0	Function Key Press the desired function key, A-D. [*] to continue 0 = Exit this mode Press the desired function key (A-D) you want to program. NOTE: A key programmed as a function key is no longer available to be used as an end-user macro key or panic key.	
Partition 1	Partition Number 1 = partition 1 2 = partition 2 3 = common partition [*] to continue Enter the partition in which the function key is active.	
Key "A" Func Zone 95 00	Define Key Function 00† = For the Function key selected, the functions are pre-defined as follows: If A selected = Zone 95 (emergency key, same as [1] [*] pair) If B selected = Zone 99 (emergency key, same as [*] [#] pair) If C selected = Zone 96 (emergency key, same as [3] [#] pair) If D selected = Single-button paging 01 = Single-button paging (sends a 999-9999 message to pager) 02 = Display time 03 = Arm AWAY (reports as User 00 if closing reports are enabled) 04 = Arm STAY (reports as User 00 if closing reports are enabled) 05 = Arm NIGHT-STAY (reports as User 00 if closing reports are enabled) 06 = Step Arming (arms STAY, then NIGHT-STAY††, then AWAY) 07 = Output Device Command (for device programmed as system operation type 66—function key in *80 Menu Mode) 08 = Communication Test (sends Contact ID code 601) 09 = Macro Key 1 (define macro by user code + [#] [6] [6] command) 10 = Macro Key 2 (define macro by user code + [#] [6] [6] command) 11 = Macro Key 3 (define macro by user code + [#] [6] [6] command) 12 = Macro Key 4 (define macro by user code + [#] [6] [6] command) [*] to continue	
† System defaults to these function key settings.		
†† If Night-Stay zones are listed in zone list 5.		
	Enter the desired function for this key, 00 to 12, from the options listed. (00 selected for example display shown at left). Press [*] to returns to key number prompt with the next function key letter displayed.	

About Descriptor Programming (*82 Menu Mode)

The system lets you assign zone descriptors for protection zones, keypad panics, and RF receiver supervision faults. Each description can be composed of a combination of words (up to 3) selected from a vocabulary of 196 words stored in memory (see a following page). In addition, up to 10 installer-defined words can be added to those already in memory, plus 3 additional words can be assigned as partition descriptors. Thus, when an alarm or trouble occurs in a zone, an appropriate description for that zone's location can be displayed at the keypad. Zone descriptors are recommended for systems using Alpha display keypads, and are necessary if a 4286 Phone Module is used.

NOTE: You can enter zone descriptors when the zone is being defined in *56 Menu mode, but we recommend you do it using *82 Menu mode.

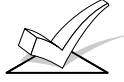

If using a 4286 Phone Module, select from those words in the Alpha Vocabulary List shown in **boldface type**. The phone module will not provide annunciation of the other words.

If a 4286 Phone Module is added to an existing system, the Alpha descriptors presently in the system should be reprogrammed, selecting from those words shown in **boldface type** in the Alpha Vocabulary List. The phone module will not provide annunciation of any other words.

Programming Zone Descriptors (Menu Mode *82)

1. Enter index numbers for up to three words from the Alpha Vocabulary List for each descriptor by following the prompts.
2. Enter up to ten 10-digit custom words, if desired, which can then be used in descriptors.

When defining descriptors:

Pressing...	Does This...
[6]	Accepts the entered index number and moves the cursor to the next position for a descriptor.
[8]	Saves the entered descriptor and moves to the next descriptor.

Start Zone Descriptor Programming mode by pressing *82 while in Data Programming mode.

Program Alpha ? 0=No, 1=Yes 00	Program Alpha <i>0 = no; 1 = yes; [*] to continue</i> The "Program Alpha ?" prompt will appear. Press 1 to continue.
Custom Words ? 0=No, 1=Yes 00	Custom Words <i>0 = no; 1 = yes; [*] to continue</i> The "Custom Words" prompt will appear. Press 0 to program standard alpha descriptors from the fixed vocabulary. The system will then automatically display the descriptor for zone 1. Press 1 to define custom words (described later in "Adding Custom Words" section).
* ZN 01	Summary Screen <i>[*] to continue</i> Note that this is a "Summary mode," and that no entries can be made. Entries can be made only when the display contains a flashing cursor, which signifies the "Entry mode." To exit the Alpha descriptor mode, press * + 0 + 0 at the summary display.
* ZN 01 <input type="checkbox"/>	Flashing Cursor <i>[*] to continue</i> To delete or change the default descriptor for zone 1, press the same zone number (01). This will clear that descriptor and allow changes to be made at the flashing cursor. NOTE: If you do not wish to change the existing descriptor for zone 1, enter the next zone number for which you wish to enter (or check) a descriptor. A summary display for that zone will appear. You must then press [*] plus the same zone number again to gain access to the entry mode (flashing cursor) for that zone.
* ZN 01 <input type="text" value="BACK"/>	First 3-Digit Index No. <i>see index for entries; [*] to continue</i> Press [#] plus the 3-digit number for the first word from the Alpha Vocabulary List. Example: If the descriptor for zone 1 is BACK DOOR. From the list, BACK = 013. Therefore, you would enter #013. If you accidentally enter the wrong word, simply press [#] plus the correct 3-digit number for the word you want.

* ZN 01 BACK
□

Accept First Word

6 = save word and go to next word in this descriptor; 8 = save word and go to next zone
Press [6] to accept the selected word and continue to the next word, or press [8] if this is the only word you are using for the descriptor.

* ZN 01 BACK
□ DOOR

Second 3-Digit Index No.

see index for entries; [*] to continue

Enter the 3-digit number for the next word. In our example, the word is DOOR, whose number is "057." Enter # 0 5 7.

* ZN 01 BACK
DOOR □

Accept Second Word

6 = save word and go to last word in this descriptor; 8 = save word and go to next zone

Press [6] to accept the selected word and continue to the next word, or press [8] if these are the only words you are using for the descriptor.

When descriptor is finished, press [8] to save all words in memory.

* ZN 01 BACK
DOOR

Summary Screen

[*] to continue

The flashing cursor will disappear, indicating that the word(s) are stored in memory for that zone, as shown in the summary display at the left.

To enter a descriptor for the next zone, press [*] plus the desired zone number. The summary display appears. Repeat the previous steps to enter the descriptor for the zone.

Adding Custom Words (will not be annunciated by 4286 Phone Module)

You can add up to 10 installer-defined words to the built-in vocabulary, which can then be used when programming zone descriptors. Each of the 10 words can actually consist of a word string of one or more words, but no more than *ten* characters can be used for each word or word string.

When adding custom words, the keypad keys perform the following functions:

[4] Moves cursor one space to the left.
[6] Moves cursor one space to the right.
[8] Saves the new word in the system's memory.

1. Select Custom Word mode (enter 1) when the prompt "CUSTOM WORD ?" is displayed.
 2. Enter the number (01–10†) of the custom word or word string to be created, corresponding to index numbers 245 - 254 respectively (for example, if you are creating the first custom word or word-string, enter 01, for the second, enter 02, etc.). A cursor will now appear at the beginning of the second line.
† or 11, 12, 13 for partition 1, partition 2 and common lobby descriptors respectively. See Assigning Partition Descriptors paragraph below.
- NOTE:** Custom words 8, 9, and 10 are "reminder words" that are programmed using Scheduling Mode.
3. Refer to the Character List of letters, numbers, and symbols on a following page.
Press [#], followed by the two-digit entry for the first letter you would like to display (e.g., # 65 for "A"). The cursor will then move to the right, in position for the next character.
To delete a character, simply enter the SPACE character (#32).
 4. Repeat Step 3 to create the desired word(s). Note that the "4" key can be used to move the cursor to the left, if necessary. Remember, no word or word-string can exceed 10 characters.
 5. Press the [8] key to save the custom word(s) and return to the "CUSTOM WORD ?" display.
Repeat Steps 2–5 for other custom words to be entered. To change a custom word, just overwrite it. If no more are to be entered now, press [0] to return to the Descriptor entry. The custom word(s) will be automatically added to the built-in vocabulary.

Assigning Partition/Custom Message Descriptors

You can assign a partition descriptor (up to 16 characters) for each partition plus the common lobby. The system displays the appropriate partition's word instead of "DISARMED READY TO ARM."

Use the same procedure as for adding custom words (described above), but use these word numbers in step 2:

11 = partition 1 _____
12 = partition 2 _____
13 = common lobby _____

Once a custom word is entered in any of these word locations (11-13), the system displays the appropriate partition's word instead of the default "DISARMED READY TO ARM" message.

ALPHA VOCABULARY LIST (For Entering Zone Descriptors)

000 (Word Space) - A - • 001 AIR • 002 ALARM * 004 ALLEY 005 AMBUSH • 006 AREA • 007 APARTMENT • 009 ATTIC * 010 AUDIO - B - • 012 BABY * • 013 BACK * • 014 BAR • 016 BASEMENT * • 017 BATHROOM * • 018 BED • 019 BEDROOM * 020 BELL • 021 BLOWER • 022 BOILER 023 BOTTOM 025 BREAK • 026 BUILDING - C - 028 CABINET • 029 CALL 030 CAMERA 031 CAR 033 CASH 034 CCTV 035 CEILING 036 CELLAR • 037 CENTRAL 038 CIRCUIT • 040 CLOSED * • 046 COMPUTER 047 CONTACT - D - • 048 DAUGHTERS 049 DELAYED • 050 DEN * 051 DESK • 052 DETECTOR * • 053 DINING * 054 DISCRIMINATOR 055 DISPLAY • 057 DOOR *	• 059 DOWN • 060 DOWNSTAIRS 061 DRAWER • 062 DRIVEWAY • 064 DUCT - E - • 065 EAST 066 ELECTRIC • 067 EMERGENCY * 068 ENTRY • 069 EQUIPMENT • 071 EXIT * 072 EXTERIOR - F - • 073 FACTORY 075 FAMILY • 076 FATHERS • 077 FENCE • 079 FIRE * • 080 FLOOR * 081 FLOW 082 FOIL • 083 FOYER 084 FREEZER • 085 FRONT * - G - • 089 GARAGE * • 090 GAS 091 GATE • 092 GLASS 093 GUEST 094 GUN - H - • 095 HALL * • 096 HEAT 098 HOLDUP 099 HOUSE * 100 INFRARED • 101 INSIDE * 102 INTERIOR 103 INTRUSION - J - 104 JEWELRY - K - • 105 KITCHEN * L - • 106 LAUNDRY * • 107 LEFT	108 LEVEL • 109 LIBRARY * • 110 LIGHT 111 LINE • 113 LIVING * • 114 LOADING 115 LOCK 116 LOOP 117 LOW • 118 LOWER - M - • 119 MACHINE 121 MAIDS 122 MAIN * • 123 MASTER * • 125 MEDICAL * 126 MEDICINE 128 MONEY 129 MONITOR • 130 MOTHERS • 131 MOTION * 132 MOTOR - N - • 134 NORTH 135 NURSERY - O - • 136 OFFICE * • 138 OPEN * 139 OPENING • 140 OUTSIDE 142 OVERHEAD - P - 143 PAINTING • 144 PANIC * 145 PASSIVE • 146 PATIO * 147 PERIMETER • 148 PHONE 150 POINT 151 POLICE * 152 POOL * • 153 POWER - R - 155 RADIO • 156 REAR 157 RECREATION 159 REFRIGERATION 160 RF	• 161 RIGHT • 162 ROOM * 163 ROOF - S - 164 SAFE 165 SCREEN 166 SENSOR • 167 SERVICE • 168 SHED * 169 SHOCK • 170 SHOP * 171 SHORT • 173 SIDE * 174 SKYLIGHT 175 SLIDING * • 176 SMOKE * • 178 SONS • 179 SOUTH 180 SPRINKLER • 182 STATION 184 STORE • 185 STORAGE * 186 STORY 190 SUPERVISED * 191 SUPERVISION 192 SWIMMING 193 SWITCH - T - 194 TAMPER 196 TELCO 197 TELEPHONE • 199 TEMPERATURE 200 THERMOSTAT • 201 TOOL 202 TRANSMITTER - U - • 205 UP • 206 UPPER • 207 UPSTAIRS * • 208 UTILITY * - V - 209 VALVE 210 VAULT 212 VOLTAGE - W - 213 WALL 214 WAREHOUSE • 216 WEST	• 217 WINDOW * • 219 WING 220 WIRELESS - X - 222 XMITTER - Y - 223 YARD - Z - 224 ZONE (No.) • 225 ZONE * • 226 0 • 227 1 • 228 1ST * • 229 2 • 230 2ND * • 231 3 • 232 3RD * • 233 4 • 234 4TH • 235 5 • 236 5TH • 237 6 • 238 6TH • 239 7 • 240 7TH • 241 8 • 242 8TH • 243 9 • 244 9TH 245 Custom Word #1 246 Custom Word #2 247 Custom Word #3 248 Custom Word #4 249 Custom Word #5 250 Custom Word #6 251 Custom Word #7 252 Custom Word #8 253 Custom Word #9 254 Custom Word #10
--	--	---	--	--

NOTE: Custom words 8, 9, 10 are "reminder words" that can be programmed to display using Scheduling Mode.

Note: Bulleted (•) words in **boldface type** are those that are also available for use by the 4286 Phone Module. If using a phone module, and words other than these are selected for Alpha descriptors, the phone module will not provide annunciation of those words.

Italicized words followed by an asterisk indicate those words supported by the 6160V/6150V Voice Keypads

CHARACTER (ASCII) CHART (For Adding Custom Words)

32 (space)	41)	50 2	59 ;	68 D	77 M	86 V
33 !	42 *	51 3	60 <	69 E	78 N	87 W
34 "	43 +	52 4	61 =	70 F	79 O	88 X
35 #	44 ,	53 5	62 >	71 G	80 P	89 Y
36 \$	45 -	54 6	63 ?	72 H	81 Q	90 Z
37 %	46 .	55 7	64 @	73 I	82 R	
38 &	47 /	56 8	65 A	74 J	83 S	
39 '	48 0	57 9	66 B	75 K	84 T	
40 (49 1	58 :	67 C	76 L	85 U	

*29 Menu Mode for IP and GSM Module Programming

This mode is for programming the Internet connection (IP) and optional VISTA-GSM4G Module configuration, collectively referred to as the Internal Device.

NOTE: The Internal Device is automatically set to address 3 and cannot be changed.

The following section describes the programming of the Internal Device using an alpha keypad. Alternatively, these options can be programmed via the AlarmNet Direct website. After programming is complete, the **control must be registered** with AlarmNet **via the Internet connection**. Refer to the Registration with AlarmNet section for procedures.

IMPORTANT: The use of the IP connection or the VISTA-GSM4G module requires an AlarmNet-I account. Please obtain the account information from the central station prior to programming this module.

Using an Alpha Keypad as a 7720P Programming Tool

When programming IP/GSM features (with *29 menu mode), the alpha keypad mimics the functions of the 7720P Programming Tool. See figure at right and table below for 7720P key functions. Each key has two possible functions: a normal function and a SHIFT function.

Normal functions: The numeric values labeled directly on the keys and the left-hand functions shown in diagram on the ABC keys. To perform a normal key function, simply press the desired key.

SHIFT functions: Those functions shown in diagram above the numerical keys and the right-hand functions shown on the ABC keys. To perform a SHIFT key function, press SHIFT key (D key), then press the desired function key (shift function is indicated by the lit READY LED).

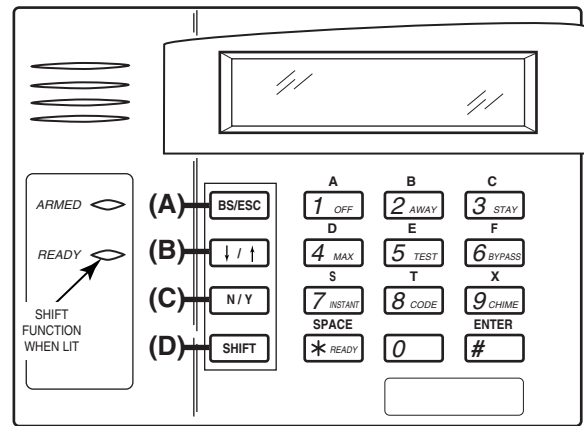

7720P Emulation Template for Alpha Keypads

Normal and SHIFT key Functions While in *29 Menu Mode

Key	Normal Key Function	SHIFT Key Function
(A) = BS/ESC	[BS]: Press to delete entry Also, can reset EEPROM defaults †	[ESC]: Press to quit Program Mode
(B) = ↓/↑	[↓]: Scroll down programming	[↑]: Scroll up programming
(C) = N/Y	[N]: Press for "NO" answer	[Y]: Press SHIFT-Y for "YES" answer
(D) = SHIFT	Press before pressing a SHIFT key function. Will light READY LED. LED goes out once a key is pressed. Press again for each SHIFT function desired.	
1/A	[1]: For entering the number 1	[A]: Used for entering C.S. ID number
2/B	[2]: For entering the number 2	[B]: Used for entering C.S. ID number
3/C	[3]: For entering the number 3	[C]: Used for entering C.S. ID number
4/D	[4]: For entering the number 4	[D]: Used for entering C.S. ID number
5/E	[5]: For entering the number 5	[E]: Used for entering C.S. ID number
6/F	[6]: For entering the number 6	[F]: Used for entering C.S. ID number
7/S	[7]: For entering the number 7	[S]: Press to display diagnostic status
8/T	[8]: For entering the number 8	[T]: Press to send TEST messages
9/X	[9]: For entering the number 9	[X]: Press to reset the IP/GSM
[*] / SPACE	[*]: Used to select programming options	[SPACE]: Not used
0	[0]: For entering the number 0	
[#] / ENTER	[#] / ENTER: Press to accept entries	No SHIFT function

† Active only when the "REVIEW?" prompt is displayed

Internal Device (IP and GSM) Default Values

The programming default values for *29 Menu Mode are listed in the Table below.

	OPTION	STANDARD DEFAULT VALUE	ACTUAL ENTRY
1	Internal Device	IP	
2	Multi-Mode	disabled	
3	Multi-Mode Address	?? (if Multi-Mode enabled)	
4	Primary City ID	??	
5	Primary CS ID	??	
6	Primary Sub ID	????	
7	Remote Access	N (disabled)	
8	Keypad Address (for remote access)	?? (if Remote Access enabled)	
9	Supervision	24 Hours	
10	GSM Rollover Y/N	N (if GSM enabled)	
11	GSM 24Hr Tst Y/N	N (if GSM enabled)	
12	Old Alarm Time	10 Minutes	
13	IP Fault Time	00 Minutes	
14	GSM Fault Time	00 Minutes (if GSM enabled)	
15	Notify Panel Of	Neither Fault (if IP and GSM enabled)	
16	Use DHCP Y/N	Y (if IP or IP/GSM enabled)	
17	NIC IP Address	255.255.255.255 (if DHCP not used)	
18	Subnet Mask	255.255.255.255 (if DHCP not used)	
19	Gateway IP Addr	255.255.255.255 (if DHCP not used)	
20	DNS IP Addr.	255.255.255.255 (if DHCP not used)	

Status and Contact ID Reporting Codes

The Internal Device (IP/GSM) sends status messages to the control panel for network connectivity failures. Trouble messages are displayed on the keypad as “Check 103,” with status displayed as “LngRng Radio” followed by a 4-digit keypad display status code, defined below.

Keypad Display Status Codes

CODE	DESCRIPTION
0000	Control panel lost communication with internal device
0005	internal device has lost contact with AlarmNet
000F	internal device is not registered; account not activated
0019	GSM module shut down
0400	internal device Power-on reset AND the control panel lost communications with IP/GSM

Contact ID Codes (as displayed at 685) sent to CS via IP/GSM

CODE	DESCRIPTION
E339 C803	Power-on reset
E350 C951	Primary communication path failure (Ethernet) **
R350 R951	Primary communication path restore (Ethernet) **
E350 C952	Secondary communication path failure (GSM) **
R350 C952	Secondary communication path restore (GSM) **
E355 C000	Module lost ECP communication with control
R355 C000	Module restore ECP communication with control
E353 C103	Long range transmitter fault trouble
R353 C103	Long range transmitter fault restore

** reports only if IP and GSM enabled

Start *29 Menu Mode by pressing *29 while in Data Programming mode.

ENABLE IP/GSM? 0=No, 1=Yes

Enable INT IP/GSM?

0 = no, not using either IP or GSM; 1 = yes using IP and/or GSM module; [*] to continue
NOTE: Default = 1 (IP and/or GSM)

IMPORTANT: If using an external communication device, first follow the instructions in the **Inadequate Signal Strength** paragraph in the **VISTA-GSM4G Module Installation** section for physical installation of an external communication device. When complete, enter 1 at this prompt and enter 1-Prog at the next prompt. Then program the external device using the Installation and Setup Guide included with the external communication device.

Fixed-Word Keypad Note: Although programming IP/GSM options cannot be done via a fixed-word keypad, IP/GSM can be enabled by doing the following:

Enter *29 (to enter IP/GSM menu mode), then press 1 + [*] + [*]

1=PROG 2=DIAG 0=QUIT

Programming/Diagnostics Select

1 = Prog (program the IP/GSM options)

2 = Diag (enter diagnostic mode) **NOTE:** If using an external communicator, Diagnostic mode option available only for communicators with firmware version 2.4.16 or higher.

0 = Quit; return to data field programming mode

Internal Device Programming Prompts

The keys used to select and enter options now follow 7720P keypad emulation. Refer to the table on the previous page for detailed key functions. The following is a summary:

- [*] = scroll the options of a particular prompt
- [#] = accept the entry and move to the next prompt
- [A] = backspace or shift-[A] for escape
- [B] = scroll to next prompt or shift-[B] scroll to previous prompt
- [C] = answer No or shift-[C] answer Yes to prompt
- [D] = shift key

Internal Device IP	Internal Device Selection <i>Disable – IP – GSM – IP & GSM</i> Select the desired type of internal device usage, IP and/or GSM (press [*] to scroll choices). Press [#] to continue
Multi mode Disabled	Multi-Mode (email reporting) <i>Disabled = no email reporting of events</i> <i>4204 Sourced = up to four types of events reported (relay numbers 1-4 report as events 1-4 respectively)</i> <i>2-4204 Sourced = up to eight types of events reported (first module's relay numbers 1-4 report as events 1-4 respectively; second module's relay numbers 1-4 report as events 5-8 respectively)</i> <i>Enhanced Reports = Enables full panel status reporting via email and reporting to TC2 web services. If used, RIS must be enabled in field *91; when enabled, address 25 is automatically assigned.</i> [#] to continue Select the desired multi mode option (press [*] to scroll choices). This feature is available only after authorization for it is set via the web-based programming tool on the AlarmNet Direct website. Multi-mode emulates 4204 Relay Module outputs to send up to four (4204 sourced) or up to eight (2-4204 sourced) reports of system events to the user via email (email address is entered at the AlarmNet Direct website). Use the AlarmNet Direct website to customize event titles, if desired. If enabled, a multi-mode address must be entered in the next prompt. Use *79/*80 Menu modes to program each emulated relay output to trigger a desired system event that, upon occurrence, will be sent to the user's email address. NOTES: 1. Multi-mode has not been evaluated by UL. 2. Multi-mode (email notification) is intended as a convenience for the user, and does not replace Central Station reporting of critical events (alarms, troubles, etc.).
Multi mode Addr (12)	Multi-Mode Address This prompt appears if Multi Mode is enabled. <i>12-15 =emulated 4204 Relay Module address.</i> <i>25 = automatically assigned if Enhanced Reports selected</i> Select the desired address. If using "2-4204-sourced," the address of the second module is automatically assigned an address one higher than the first module's address. NOTE: A 4204 Relay module address is required for multi-mode purposes, but an actual 4204 Relay module is not used at the selected address.
Primary City ID (??)	Primary City ID NOTE: Account information is provided by the central station administrator. <i>01-99 (decimal) = 2-digit primary city code</i>
Primary CS ID (??)	Primary CS ID <i>01-FE (HEX)</i> Enter the primary central station's system ID number,
Primary Sub ID (????)	Primary Subscriber ID <i>0001-9999 (decimal)</i> Enter the 4-digit customer account number.
Remote AccessY/N (N)	Remote Access This feature is available only after authorization for it is set via the web-based programming tool on the AlarmNet Direct website. <i>[Y] = use remote services</i> <i>[N] = do not use remote services</i> [#] to continue Remote Services allow the end user to access their security system from their computer via the remote services (ex. Total Connect) website. Most system functions can then be performed.

Keypad Address
(28)

Keypad Address (for Remote Access)

This prompt appears if remote access is enabled.

1, 2, 5, 6 = emulated AUI address
17-23 = emulated standard keypad address

For enhanced remote access features, choose an AUI address. If no AUI addresses are available (all four AUIs are being used), choose an available standard keypad address (some remote access features will be unavailable).

NOTE: An AUI or standard keypad address is required for remote access purposes, but an actual AUI device or keypad is not used at the selected address.

Supervision
24 Hours

Supervision

<i>if using IP and/or GSM</i>	<i>if using IP only (not for GSM usage)</i>
-------------------------------	---

- | | |
|---|---|
| <ul style="list-style-type: none"> • 30 day • 24-hours • None (no supervision) | <ul style="list-style-type: none"> • US UL Line (6 Min) • US UL Line (90 Sec) • CN UL Line Lv1 3 (3 Min) • CN UL Line Lv1 4 (90 Sec) • CN UL Line Lv1 5 (75 Sec) • 1 hour |
|---|---|

To scroll the choices: [*] key scrolls forward; [backspace] key scrolls backward [#] to continue

The supervising station must hear from the IP/GSM at least once during the supervision period. AlarmNet transmits a communications failure alarm to the central station if the supervision message is not received within the period.

This selection sets the supervision timing for one of the following values:

GSM Rollover Y/N
(N)

GSM Rollover

Appears only if IP & GSM is selected as Internal Device option.

[Y] = all messages (including AlarmNet network supervisory messages) are sent over the GSM network in the event of an Internet failure

[N] = all messages (except AlarmNet network supervisory messages) are sent automatically over the GSM network in the event of an Internet failure

GSM 24Hr Tst Y/N
N

GSM 24Hr Tst

Appears only if IP & GSM is selected as Internal Device option.

[Y] = have a message sent once a day to verify GSM operation. A "secondary communication path loss" message is generated if the message is not successfully delivered.

[N] = disable 24hr test

Old Alarm Time
10 Minutes

Old Alarm Time

The old alarm time sets how long an undeliverable alarm is retried for delivery to AlarmNet. If the message is not validated, it is retried until the old alarm time is reached or the message is validated. The choices available are:

- | | |
|--------------|------------|
| • 10 Minutes | • 4 Hours |
| • 15 Minutes | • 8 Hours |
| • 30 Minutes | • 12 Hours |
| • 1 Hour | • 24 Hours |
| • 2 Hours | |

To scroll the choices: [*] key scrolls forward; [backspace] key scrolls backward [#] to continue

IP Fault Time
(00 mins)

IP Fault Time

Appears only if IP or IP & GSM is selected as Internal Device option.

00-99 = time delay (in minutes) before the control notifies the central station that there is a loss of contact with the network over the Ethernet (IP) connection.

0 = no delay (valid only if using IP only)

Must be two (2) minutes for UL installations.

GSM Flt Time
(00 mins)

GSM Flt Time

Appears only if GSM or IP & GSM is selected as Internal Device option.

00-99 = time delay (in minutes) before the control notifies the central station that a loss of contact with AlarmNet network has occurred.

0 = no delay (valid only if using GSM only)

Must be two (2) minutes for UL installations.

Notify Panel Of _ Neither Fault

Notify Panel Of

Appears only if IP & GSM is selected as Internal Device option.
Select from the following choices:

- *Neither Fault*
- *Both IP and GSM must fail before fault code is sent (status code 4005 displayed); panel receives primary and secondary path failure messages. No message sent if only one or the other path fails.*

To scroll the choices: [*] key scrolls forward; [backspace] key scrolls backward

- [#] to continue

NOTE: IP failure will always be sent to the central station as Primary Path Failure, and GSM failure will always be sent as Secondary Path Failure.

IP address information prompts

The following prompts appear only if IP or IP & GSM is selected as Internal Device.

It is recommended to use dynamically allocated IP addresses, but if fixed IP addresses are desired, contact your network administrator for the appropriate information.

NOTE: A valid IP address must be entered in each prompt before the system continues to the next prompt.

Entries cannot be left with the default values.

Use DHCP Y/N (Y)

Use DHCP

[Y] = have the IP addresses dynamically allocated (recommended), skip to Review prompt.

[N] = use fixed IP addresses; continue with next prompt

[#] to continue

NIC IP Address 255.255.255.255

NIC IP Address

Enter the 4-part IP address for this device, separating each part with a space ([*] key, displayed as periods).

[#] to continue

Subnet Mask 255.255.255.255

Subnet Mask

Enter the 32-bit address mask used to indicate the portion (bits) of the IP address that is being used for the subnet address, separating each part with a space ([*] key, displayed as periods).

[#] to continue

Gateway IP Addr 255.255.255.255

Gateway IP Addr

Enter the 4-part IP address assigned to the Gateway, separating each part with a space ([*] key, displayed as periods). If unused set to 0.0.0.0.

[#] to continue

DNS IP Addr 255.255.255.255

DNS IP Addr

Enter the 4-part IP address assigned to the DNS (Domain Name System) server, separating each part with a space ([*] key, displayed as periods). If unused set to 0.0.0.0.

[#] to continue

Review? Y/N

Review (and Exit *29 Menu mode or Reset Defaults)

You can review the *29 Menu mode options to ensure that the correct responses have been made. When satisfied with entries, select [N] to exit *29 Menu mode.

To review prompts or exit *29 Menu mode:

[Y] = review prompts and entries, starting with Internal Device. Use the up/down arrow keys to scroll through the program fields without changing any of the values. If a value requires change, simply type in the correct value. When the last field is displayed, the "REVIEW?" prompt again appears.

[N] = Exit *29 menu mode and return to data field programming mode. The prompt briefly displays "DONE" before returning to data field mode prompt "Enter * or #."

[#] to accept Y or N selection (# alone exits same as N)

To reset *29 Menu mode defaults:

Press [ESC] at the Review prompt to display the "Reset Factory Defaults" prompt.

[Y] = reset *29 menu mode options to factory values; if selected, all programmed *29 Menu mode options are reset to the factory settings

[N] = cancel reset defaults function

Programming IP/GSM Options via AlarmNet Direct Website

To program the IP/GSM options via the AlarmNet Direct website (if you are already signed up for this service), go to: <https://services.alarmnet.com/AlarmNetDirect/userlogin.aspx>

If you are not signed up for this service, click on “Dealer Sign-Up.”

Log in and follow the on-screen prompts.

Please have the following information available:

1. Primary City ID (two-digit number)
2. Primary Central Station ID (two-digit hexadecimal number)
3. Primary Subscriber ID (four-digit number)
4. MAC ID and MAC CRC number (located on the outside of box and on label inside module) or MIN number of the device you are replacing
5. Mode of operation of existing module if replacing a "C" series radio.

After programming is complete, you must transfer the data to the module and the module must be registered. Refer to the Registration section for details.

IP/GSM Diagnostic Commands (*29 Menu Mode)

Diagnostic commands can be used to quickly view your Internet and GSM connectivity settings and options. For each command (except [↓] and [0]) press the [shift] key and then the designated command key. For example, press [shift] then [1/A] to display the software revision screen.

To enter Diagnostic mode:

1. Press *29 while in data field programming mode.
2. Enter “1” at the “Enable IP/GSM” prompt then press [*].
3. Select “2” (Diag) at the next prompt.
4. Enter the desired command at the “Sel Key Command” prompt.

For subsequent commands, enter the next command at the currently displayed screen.

To exit Diagnostic mode, press ESC (shift-[A]).

Key	Prompt	Function
[A]	INTERNAL IP/GSM x.x.xx mm/dd/yy	Software Revision "x.x.xx" indicates the installed software Revision. Mm/dd/yy indicates month, day and year of the revision.
[B]	MAC xxxxxxxxxxxx MAC CRC yyyy	MAC, SCID, IMEI "xxxxxxxxxxxx" indicates the IP/GSM's unique identification number. Yyyy indicates the 4 digit MAC CRC needed to enroll the device in dealer direct. [*] to go to SCID.
	SCID xxxxx xxxxx xxxxx xxxxx	Only if GSM or IP/GSM enabled. Displays the identification number assigned to the SIM card (SCID) in this device. [*] to go to IMEI.
	IMEI xxxxxxxx Xxxxxx x	Only if GSM or IP/GSM enabled. Displays the identification number assigned to the GSM module in this device. [*] returns to MAC.
[C]	Mon 01 Jan 2006 05:48:39 am	Time Retrieves the current date and time from the AlarmNet network in Greenwich Mean Time (GMT). This display confirms that the module is in sync with network.

Key	Prompt	Function
[D]	Physical Link Good/Bad	Physical Link Only if IP or IP/GSM enabled. Indicates whether the device has detected a physical connection to the internet. [*] to continue to NIC IP address.
	NIC IP Address xxx.xxx.xxx.xxx	IP Information Displays Displays the IP address assigned to this device. [*] to go to subnet mask.
	Subnet Mask xxx.xxx.xxx.xxx	Displays the 32-bit address mask used to indicate the portion (bits) of the IP Address that is being used for the subnet address. [*] to go to gateway IP.
	Gateway IP Addr xxx.xxx.xxx.xxx	Displays the IP Address assigned to the Gateway. [*] to go to DNS server IP.
	DNS Serv IP xxx.xxx.xxx.xxx	Displays the IP Address assigned to the DNS (Domain Name System) server. [*] to go to encryption test.
	Encryption Test AES Passed!	Performs a self-test of the AES encryption algorithm. [*] to go to DHCP.
	DHCP OK	DHCP (Dynamic Host Configuration Protocol) indicates server is okay. [*] returns to Physical Link prompt.

IP/GSM Diagnostic Commands (continued)

Key	Prompt	Function																												
[E]	<table border="1"> <tr> <td>PriRSSI</td> <td>3/4G</td> <td>REG</td> </tr> <tr> <td>-xxxdbm</td> <td>stat</td> <td>x</td> </tr> </table> <p>or</p> <table border="1"> <tr> <td>PriRSSI</td> <td>2G</td> <td>REG</td> </tr> <tr> <td>-xxxdbm</td> <td>stat</td> <td>x</td> </tr> </table> <p>2G Network Stat can be :</p> <table border="1"> <tr> <td>Good</td> <td>-20 to -89 dBm</td> </tr> <tr> <td>OK</td> <td>-90 to -98 dBm</td> </tr> <tr> <td>Marg.</td> <td>-99 to -104 dBm</td> </tr> <tr> <td>Bad</td> <td>-105 to -150 dBm</td> </tr> </table>	PriRSSI	3/4G	REG	-xxxdbm	stat	x	PriRSSI	2G	REG	-xxxdbm	stat	x	Good	-20 to -89 dBm	OK	-90 to -98 dBm	Marg.	-99 to -104 dBm	Bad	-105 to -150 dBm	<p>GSM Status Displays</p> <p>Only if GSM or IP/GSM enabled.</p> <p>PriRSSI – Primary Site RSSI level in dbm</p> <p>3/4G – Communicator is on the 3G/4G network where “stat” can be:</p> <table border="1"> <tr> <td>Good</td> <td>RSSI -20 to -90 dBm</td> </tr> <tr> <td>OK</td> <td>RSSI -91 to -99 dBm</td> </tr> <tr> <td>Marginal</td> <td>RSSI -100 to -105 dBm</td> </tr> <tr> <td>Bad</td> <td>RSSI -106 to -150 dBm</td> </tr> </table> <p>REG – Registration status from GSM module where “x” can be:</p> <p>N – Not Registered H – Registered Home S – Searching D – Registration Denied R – Registered Roaming ? – Unknown Reg. State</p> <p>[*] to continue to next screen.</p>	Good	RSSI -20 to -90 dBm	OK	RSSI -91 to -99 dBm	Marginal	RSSI -100 to -105 dBm	Bad	RSSI -106 to -150 dBm
PriRSSI	3/4G	REG																												
-xxxdbm	stat	x																												
PriRSSI	2G	REG																												
-xxxdbm	stat	x																												
Good	-20 to -89 dBm																													
OK	-90 to -98 dBm																													
Marg.	-99 to -104 dBm																													
Bad	-105 to -150 dBm																													
Good	RSSI -20 to -90 dBm																													
OK	RSSI -91 to -99 dBm																													
Marginal	RSSI -100 to -105 dBm																													
Bad	RSSI -106 to -150 dBm																													
	<table border="1"> <tr> <td>RAT</td> <td>EC/NO</td> </tr> <tr> <td>3/4G</td> <td>-xxxxx</td> </tr> </table>	RAT	EC/NO	3/4G	-xxxxx	<p>RAT = Radio Access Technology</p> <p>EC/NO = Carrier Noise Ratio (EC/NO does not apply to 2G network ; displays N/A)</p> <p>[*] to continue to next screen.</p>																								
RAT	EC/NO																													
3/4G	-xxxxx																													
	<table border="1"> <tr> <td>Cntry Netw</td> <td>LAC</td> </tr> <tr> <td>xxx xxx</td> <td>xxxxx</td> </tr> </table>	Cntry Netw	LAC	xxx xxx	xxxxx	<p>Cntry – Country Code</p> <p>Netw – Network Code</p> <p>LAC – Reg. status from GSM.</p> <p>[*] to continue to next screen.</p>																								
Cntry Netw	LAC																													
xxx xxx	xxxxx																													
	<table border="1"> <tr> <td>Cell BaseSt Chan</td> </tr> <tr> <td>Xxxxx x xxx</td> </tr> </table>	Cell BaseSt Chan	Xxxxx x xxx	<p>Cell – Base Station ID</p> <p>BaseSt – Base Station Antenna Sector</p> <p>Chan – Control Channel in use</p> <p>[*] to continue to next screen.</p>																										
Cell BaseSt Chan																														
Xxxxx x xxx																														
	<table border="1"> <tr> <td>Second Site RSSI</td> </tr> <tr> <td>-xxxdbm</td> </tr> </table>	Second Site RSSI	-xxxdbm	<p>Secondary GSM Site RSSI level in dbm.</p> <p>[*] to continue to next screen.</p>																										
Second Site RSSI																														
-xxxdbm																														
[F]	<table border="1"> <tr> <td>Testing Gateway</td> </tr> <tr> <td>Redir 1</td> </tr> </table>	Testing Gateway	Redir 1	<p>Network Diagnostic Test</p> <p>Only if IP or IP/GSM enabled.</p> <p>Performs a set of network diagnostics that tests the integrity of the links between the IP/GSM and the various connection points (Redirs) to AlarmNet.</p>																										
Testing Gateway																														
Redir 1																														

Key	Prompt	Function			
[S]	<table border="1"> <tr> <td>FLT</td> </tr> <tr> <td>OK</td> </tr> </table>	FLT	OK	<p>Status request</p> <p>OK = normal i = IP off line I = IP fault reported g = GSM off line G = GSM fault reported</p>	
FLT					
OK					
[T]	<table border="1"> <tr> <td>Test Msg Sent</td> </tr> </table>	Test Msg Sent	<p>Test Alarm</p> <p>Sends a Test alarm to AlarmNet. Functional for a registered IP/GSM only. If the device is not registered, a message is displayed indicating that the command cannot be executed.</p>		
Test Msg Sent					
[X]	<table border="1"> <tr> <td>Reset CPU Y/N</td> </tr> </table>	Reset CPU Y/N	<p>Reset the IP/GSM.</p> <p>[N] = return to diagnostic mode (blank screen = enter next command or escape).</p> <p>[Y] = resets the module (blank screen = when reset complete, enter next command or escape).</p>		
Reset CPU Y/N					
[↑]	<table border="1"> <tr> <td>Registering ...</td> </tr> </table>	Registering ...	<p>Registration (Shift-UP arrow)</p> <p>Registers a programmed IP/GSM with AlarmNet. If it is configured to report to AlarmNet, the IP/GSM will register with AlarmNet.</p>		
Registering ...					
[↓]	<table border="1"> <tr> <td>Enter PIN#</td> </tr> </table>	Enter PIN#	<p>Registration with PIN for Replacement Module (DN arrow)</p> <p>Registers a programmed IP/GSM with AlarmNet if it is configured to report to AlarmNet.</p>		
Enter PIN#					
[0]	<table border="1"> <tr> <td>Force Server Update Y/N</td> </tr> </table>	Force Server Update Y/N	<p>Force Upload of Configuration File to Server</p> <p>[Y] = force the device to upload its entire configuration file to the server.</p> <p>[N] = cancel the operation.</p> <p>NOTE: If the internet is not available, and the module is not initialized when you enter this command, the following screen will be displayed:</p> <table border="1"> <tr> <td>Cannot Upload</td> </tr> <tr> <td>Try Later! _</td> </tr> </table> <p>Wait for the RSSI LEDs to light, indicating the module has completed its initialization, and try again.</p>	Cannot Upload	Try Later! _
Force Server Update Y/N					
Cannot Upload					
Try Later! _					

Registering the Control with AlarmNet

The control must be registered with AlarmNet before internet communication (via IP or GSM) can occur.

To register, the control must be connected to the Internet.

Register the control by using one of these methods:

Register by phone

1. Call 1-800-222-6525

You will need the following information:

- MAC ID and MAC CRC number (found on the label)
 - Subscriber information (provided by the central station), including a city code, CSID, and a subscriber ID
 - Activation ID (AID) and AID CRC numbers (found on the module's label or on its carton)
2. When instructed to do so, triple-click the Test switch to complete the registration.

Register with AlarmNet Direct Website

To register via AlarmNet Direct Website, please go to:

<https://services.alarmnet.com/AlarmNetDirect/userlogin.aspx>.

Log in and follow the on-screen prompts. Please have the following information available:

- Primary City ID (two-digit number provided by central station)
- Primary Central Station ID (two-digit hexadecimal number provided by central station)
- Primary Subscriber ID (four-digit number provided by central station)
- MAC ID and MAC CRC number (located on outside of box and on label on control's PC board)
- Activation ID (AID) and AID CRC numbers (found on the module's label or on its carton)

If you are not signed up for this service, click on "Dealer Signup" from the login screen to gain access to the Honeywell web-based programming.

Dealer Sign-Up Direct Link: https://services.alarmnet.com/AlarmNetDirectP_Sign-Up.

You will be instructed how to proceed upon completing the sign-up form. Only one sign-up per dealer is required. Once an initial user is established, additional logins may be created by that user.

Once the control is registered, you may log out of the AlarmNet Direct website.

Register with Alpha Keypad using *29 Menu mode

1. Enter *29 Menu mode, select Diagnostic mode, then press Shift then [↑] key (D key followed by the B key). The registration message is sent ("Registering" displayed) and the control waits for the acknowledgment.
2. "Registration SUCCESS" displayed, indicating successful registration.

Register with Test Switch on control's PCB (triple-click)

1. Click the switch three times.
2. Watch the GSM Status LEDs: The Message (yellow) LED and the Status (green) LED will blink slowly in unison while registration is in progress.
3. When registration is complete, the Status (green) LED goes out.

Upload/Download via the Internet

This control supports upload/download programming capability via the Internet by using the AlarmNet network and Compass downloading software. The control must be connected to the Internet (via the on-board RJ45 connector or VISTA-GSM4G module), have all IP features programmed (*29 Menu mode), and be registered with AlarmNet. The following is required at the Downloading Office:

- Broadband Internet Access and Broadband (Cable/DSL) Modem
- Broadband (Cable/DSL) Router (optional, if connecting more than one device to the Internet)
- Computer running Compass Downloading Software version that supports Internet upload/download for this control.

To perform upload/download functions:

1. Connect the computer to the Internet and start the Compass downloading software.
2. Open the control's account, then select the Communications function and click the **Connect** button.
3. At the Connect screen, check that the control's MAC address is entered and the TCP/IP checkbox is checked.
4. Click **Connect**. The Internet connection to the control is made automatically via AlarmNet.
5. Once connected, use the Compass downloading software as normal to perform upload/download functions.

Programming Installer and User Schedules

The system provides up to 32 schedules, which can be used to automatically control 11 types of system events at pre-defined times. Some events are reserved for the installer only.

There are 16 schedules for use by the end-user, 16 for use by the installer.

NOTES:

- The master code can only access schedules 01-16 and events 00-07.
- System clock must be set before schedules can be used.
- Programmed schedules do not take effect until the next scheduled “start” time. (e.g., if programming a schedule time window for 8AM to 5PM, the schedule does not take effect until 8AM after the schedule has been programmed.)

Start Scheduling mode by entering installer code + [#] + [6] [4] while in normal operating mode.

<div style="border: 1px solid black; padding: 5px;"> ENTER SCHED NO. 00=QUIT 00 </div>	Schedule Number <i>01-16 = end-user schedules</i> <i>17-32 = installer-only schedules</i> [*] to continue Enter the desired schedule number.										
<div style="border: 1px solid black; padding: 5px;"> ENTER EVENT </div>	Enter Event <table style="width: 100%; border: none;"> <tr> <td style="width: 50%; border: none;"><i>00 = clear event</i></td> <td style="width: 50%; border: none;"><i>05 = Forced Away Arming†</i></td> </tr> <tr> <td style="border: none;"><i>01 = Relay On/Off</i></td> <td style="border: none;"><i>06 = Auto Disarm</i></td> </tr> <tr> <td style="border: none;"><i>02 = User Access</i></td> <td style="border: none;"><i>07 = Display “Reminder”</i></td> </tr> <tr> <td style="border: none;"><i>03 = Latch Key Report to Pager</i></td> <td style="border: none;"><i>10 = Display custom words ††</i></td> </tr> <tr> <td style="border: none;"><i>04 = Forced Stay Arming†</i></td> <td style="border: none;"><i>11 = Periodic Test Report†††</i></td> </tr> </table>	<i>00 = clear event</i>	<i>05 = Forced Away Arming†</i>	<i>01 = Relay On/Off</i>	<i>06 = Auto Disarm</i>	<i>02 = User Access</i>	<i>07 = Display “Reminder”</i>	<i>03 = Latch Key Report to Pager</i>	<i>10 = Display custom words ††</i>	<i>04 = Forced Stay Arming†</i>	<i>11 = Periodic Test Report†††</i>
<i>00 = clear event</i>	<i>05 = Forced Away Arming†</i>										
<i>01 = Relay On/Off</i>	<i>06 = Auto Disarm</i>										
<i>02 = User Access</i>	<i>07 = Display “Reminder”</i>										
<i>03 = Latch Key Report to Pager</i>	<i>10 = Display custom words ††</i>										
<i>04 = Forced Stay Arming†</i>	<i>11 = Periodic Test Report†††</i>										
<div style="border: 1px solid black; padding: 5px;"> NOTE: Events 07 and 10 cause the keypad to beep every 30 seconds when messages are displayed. Stop the beeps by pressing any key. </div>	<p><i>Press [*] to continue</i> Enter the desired event number for event you want to occur at a specified time. Events 10-11 are reserved for the installer only.</p> <p>Latch key report (option 03) is sent to all pagers in the user’s partition and is active only when the system is armed (message sent is 777-7777). User must be enabled for paging (see User Attributes in System Operation section).</p> <p>† Forced bypass is automatically enabled regardless of setting in field *23. †† If selected, system displays custom words 8, 9, and 10 at defined time. Can be used as installer’s reminder message to the end user. ††† See key commands in Testing the System section to quickly set periodic test reporting intervals.</p>										
<div style="border: 1px solid black; padding: 5px;"> DEVICE NUMBER XX </div>	Device Number (For event 01-relay on/off) <i>01-18 = device number; press [*] to continue</i> Enter the physical device number as programmed in *79 Menu Mode, then press [*] to continue to the “Start” prompt. Device numbers 17 and 18 designate built-in triggers 1 and 2 respectively.										
<div style="border: 1px solid black; padding: 5px;"> GROUP NUMBER X </div>	Group Number (For event 02-user access) <i>1-8 = group number; press [*] to continue to the “Start” prompt</i>										
<div style="border: 1px solid black; padding: 5px;"> PARTITION X </div>	Partition (For events 03-07, 10) <i>0 = all partitions; 1 = partition 1; 2 = partition 2; 3 = common</i> <i>Press [*] to continue to the “Start” prompt.</i>										
<div style="border: 1px solid black; padding: 5px;"> START SMTWTFSS HH MMAM 0010000 </div>	Start Time <i>01-12 = hour; 00-59 = minute; 0 = AM; 1 = PM; Days = place “1” under days</i> <i>Press [*] to continue.</i> Enter the event’s start time and days of the week to occur. To select days, position the cursor under the desired days using the [*] key to move forward, then press “1” to select the day.										

STOP	SMTWTFS
HH MMAM	0010000

Stop Time (For events 01-relay on/off; 02-user access; 03-latch key report)
 01-12 = hour; 00-59 = minute; 0 = AM; 1 = PM; Days = place "1" under days
 Press [*] to continue.

Enter the event's stop time and days of the week to occur.
 To select days, position the cursor under the desired days using the [*] key to move forward, then press "1" to select the day.

REPEAT OPTION	
0-4	X

Repeat Option
 0 = do not repeat; 1 = repeat weekly; 2 = repeat biweekly (every other week)
 3 = repeat every third week; 4 = repeat every fourth week
 Press [*] to continue.

Enter the desired repeat option for this schedule.
 e.g., To make a schedule that happens everyday you would select all days with a repeat count of 1. To make a schedule that runs for one week then stops, select everyday with a repeat count of 0.

RANDOMIZE	
0=NO 1=YES	X

Randomize (For events 01 and 11)
 0 = no; 1 = yes
 Press [*] to continue.

If selected, the scheduled start and stop times will vary within 60 minutes of the "hour" time. For example, if a schedule is set to start at 6:15pm, it will do so the first time 6:15pm arrives, but on subsequent days it will start anytime between 6:00 and 6:59 p.m.

NOTE: Do not use the random option if the start and stop times are within the same "hour" setting, otherwise unpredictable results may occur (e.g., the randomized stop time may occur before the start time).

AVS System Enable and Quick Programming Commands

Applies to an AVS system using an ECP connection to the control.

1. Install the AVS module according to its instructions.
2. Use one of the control's AVS Quick Program commands as follows (see Quick Program Command Results below for results of each command):
 - **installer code + [#] + 0 + 3:** enable AVS operation without panel sounds on the AVST speaker
 - **installer code + [#] + 0 + 4:** enable AVS operation and enable panel sounds on the AVST speaker
3. Use data field *55 Dynamic Signaling Priority to enable the reporting path for AAV communication.
4. To undo the Quick Command programming, use the following commands:
 - **installer code + [#] + 0 + 5:** remove all options set by [#] + 03 quick command
 - **installer code + [#] + 0 + 6:** remove all options set by [#] + 04 quick command

Quick Program Command Results

When either the #03 or #04 Quick Program command is used, the following are automatically programmed and no longer available for other control panel purposes.

Pre-Programmed	#03 Command	#04 Command
Output Function No. (*80 mode)	46 (zone type 60, relay 15) 47 (zone type 61, relay 16) 48 (zone type 62, relay 16)	Same as #03 plus: 41 (zone type 14, relay 13) 42 (zone type 22, relay 13) 43 (zone type 39, relay 14) 44 (zone type 33, relay 14) 45 (zone type 36, relay 14)
Output Relay No. (*79 mode)	15 (addr 11, relay pos 2) 16 (addr 11, relay pos 1)	Same as #03 plus: 13 (addr 11, relay pos 4) 14 (addr 11, relay pos 3)
Protection Zone (*56/*58 mode)	4229 zn 48 (zt 81, addr 11)	Same as #03 command
Device Address	address 11 (AVS module)	Same as #03 command
Data Field *91	AAV enabled	AAV enabled

System Communication and Operation

Panel Communication with Central Station

This system accommodates several formats for reporting alarms and other system conditions to the Central Station. The process of a successful transmission consists of both the method of communication between the control panel and the Central Station receiver; and the actual way the information is sent and displayed at the Central Station.

When the panel calls the Central Station receiver, it waits to hear a “handshake” frequency from the receiver to confirm that the receiver is on-line and ready to receive its message. Once the panel hears the handshake it is programmed to listen for, it sends its message. The panel then waits for a “kissoff” frequency from the receiver acknowledging that the message was received and understood.

If the handshake frequency is not given or is not understood by the panel, the panel will not send its message. Once the handshake frequency is received and understood by the panel, the panel sends its message. If there is an error in the transmission (the receiver does not receive a “valid” message), the kissoff frequency is not given by the Central Station receiver.

The panel makes a total of eight attempts to the primary telephone number and eight attempts to the secondary telephone number (if programmed) to get a valid message through. If the panel is not successful after its numerous attempts, the keypad displays COMM. FAILURE (on alpha keypads) or FC (on fixed-word keypads).

Report Code Formats

The following chart indicates the types of (handshake/kissoff) frequencies that the panel supports and the different formats that can be sent with each.

FORMAT	HANDSHAKE	TRANSMITS DATA	KISSOFF	TRANSMIT TIME
Low Speed 3+1, 4+1, 4+2	1400 Hz	1900Hz (10PPS)	1400 Hz	Under 15 secs (Standard report)
Sescoa/Rad 3+1, 4+1, 4+2	2300 Hz	1800Hz (20PPS)	2300 Hz	Under 10 secs (Standard report)
Express 4+2	1400–2300 Hz	DTMF (10 cps)	1400 Hz	Under 3 secs
Contact ID	1400–2300 Hz	DTMF (10 cps)	1400 Hz	Under 3 secs

The following table describes each format in greater detail.

FORMAT TYPE	DESCRIPTION
3+1 and 4+1 Standard Formats	Comprises a 3- (or 4-) digit subscriber number and a single-digit report code (e.g., Alarm, Trouble, Restore, Open, Close, etc).
3+1 and 4+1 Expanded Formats	Comprises a 3- (or 4-) digit subscriber number and a two-digit report code. The first digit is displayed on the first line. On the second line, it is repeated 3 (or 4) times and is followed by the second digit. This is the “expanded” digit.
4+2 Format	Comprises a 4-digit subscriber number and 2-digit report code.
ADEMCO Contact ID Reporting Format	Comprises a 4- or 10-digit subscriber number (depending on format selected), 1-digit event qualifier (“new” or “restore”), 3-digit event code, and 3-digit zone number, user number, or system status number (see the following page).

The following table lists codes for reports sent in different formats:

Type of Report	Code for 3+1/4+1 Standard	Code for 3+1/4+1 Expanded	Code for 4+2
Alarm	SSS(S) A	SSS(S) A AAA(A) Z	SSSS AZ
Trouble	SSS(S) T	SSS(S) T TTT(T) t	SSSS Tt
Bypass	SSS(S) B	SSS(S) B BBB(B) b	SSSS Bb
AC Loss	SSS(S) E	SSS(S) E EEE(E) A _C	SSSS EA _C
Low Batt	SSS(S) L	SSS(S) L LLL(L) L _B	SSSS LL _B
Open	SSS(S) O	SSS(S) O OOO(O) U	SSSS OU
Close	SSS(S) C	SSS(S) C CCC(C) U	SSSS CU
Test	SSS(S) G	SSS(S) G GGG(G)g	SSSS Gg
Restore Alarm	SSS(S) R	SSS(S) R RRR(R) Z	SSSS RZ
AC Restore	SSS(S) R _A	SSS(S) R _A R _A R _A R _A (R _A)A _c	SSSSR _A A _c
LoBat Res.	SSS(S) R _L	SSS(S) R _L R _L R _L R _L (R _L)L _B	SSSS R _L L _B
Trouble Res.	SSS(S) R _T	SSS(S) R _T R _T R _T R _T (R _T)t	SSSS R _T t
Bypass Res.	SSS(S) R _B	SSS(S) R _B R _B R _B R _B (R _B)b	SSSS R _B b

Where:

- | | |
|---|---|
| SSS or SSSS = Subscriber ID | C = Close Code—1st Digit |
| A = Alarm Code—1st digit | U = User Number (in hex) |
| Z = Typically Zone Number*—2nd digit | Gg = Test Code (1st & 2nd digits) |
| Tt = Trouble Code (1st & 2nd digits) | R = Restore Code (Alarm) |
| Bb = Bypass Code (1st & 2nd digits) | R _T t = Restore Code (Trbl) 1st & 2nd digits |
| EA _C = AC Loss Code (1st & 2nd digits) | R _B b = Restore Code (Byps) 1st & 2nd digits |
| LL _B = Low Battery Code (1st & 2nd digits) | R _A A _C = Restore Code (AC) 1st & 2nd digits |
| O = Open Code—1st Digit | R _L L _B = Restore Code (Bat) 1st & 2nd digits |

*Zone numbers for: * & #, or B = 99; 1 + *, or A = 95; 3 + #, or C = 96; Duress = 92

Ademco Contact ID®

The Ademco Contact ID® Reporting Format comprises the following:

- 4-digit or 10-digit subscriber number (depending on format selected).
- 1-digit event qualifier (“new” or “restore”).
- 3-digit event code.
- 2-digit Partition No.
- 3-digit zone number, user number, or system status number (see the following page).

Ademco Contact ID® Reporting takes the following format: CCCC(CCCCC) Q EEE GG ZZZ

where:

CCCC(CCCCC) = Customer (subscriber) ID

Q = Event qualifier, where:

E = new event , and R = restore

EEE = Event code (3 hexadecimal digits)

Note: For a complete list of event codes, refer to the central office receiver manual.

GG = Partition Number (system messages show “00”)

ZZZ = Zone/contact ID number reporting the alarm, or user number for open/close reports. System status messages (AC Loss, Walk Test, etc.) contain zeroes in the ZZZ location.

TABLE OF CONTACT ID EVENT CODES
(some event codes may not apply to certain control panels)

Code	Definition
110	Fire Alarm
121	Duress
122	Alarm, 24-hour Silent
123	Alarm, 24-hour Audible
131	Alarm, Perimeter
132	Alarm, Interior
134	Alarm, Entry/Exit
135	Alarm, Day/Night
143	Alarm, Expansion Module
145	ECP Module cover tamper
146	Silent Burglary
150	Alarm, 24-Hour Auxiliary/Monitor zone
162	Carbon Monoxide
301	AC Power
302	Low System Battery/Battery Test Fail
305	System Reset (Log only)
321	Bell/Siren Trouble
333	Trouble, Expansion Mod. Supervision
341	Trouble, ECP Cover Tamper
344	RF Receiver Jam
351	Telco Line Fault
353	Long Range Radio Trouble
354	Comm Fail (log only)
373	Fire Loop Trouble
374	Exit Error Alarm
380	Global Trouble, Trouble Day/Night

Code	Definition
381	RF Sensor Supervision
382	Supervision Auxiliary Wire Zone
383	RF Sensor Tamper
384	RF Sensor Low-battery
393	Clean Me
401	Disarmed, Armed AWAY, Armed MAXIMUM
403	Schedule Arm/Disarm AWAY
406	Cancel by User
407	Remote Arm/Disarm (Downloading)
408	Quick Arm AWAY
409	Keyswitch Arm/Disarm AWAY
441	Disarmed/Armed STAY/INSTANT, Quick-Arm STAY/INSTANT
442	Keyswitch Arm/Disarm STAY
455	Scheduled Arm Fail
459	Recent Closing
570	Bypass
601	Manually Triggered Dialer Test
602	Periodic Test
606	AAV to Follow
607	Walk Test Entered/Exited
623	Event Log 80% Full
625	Real-Time Clock was Changed (log only)
627	Program Mode Entry (log only)
628	Program Mode Exit (log only)
642	Latch Key (log only)
750 - 789	Reserved for Configurable Zone Type report codes (check with central station when using these codes)

System Security Codes

The systems provides one Installer code, one System Master code, plus a set of other user codes intended for other users of the system. These codes can each be assigned one of 5 authority levels, which determine the functions each code can perform as listed in the table below.

Number of Codes: Provides 48 security codes (plus Installer code), including one System Master code, two Partition Master codes, and 45 general user codes.

Authority Levels (can be assigned to users 03-49 only; users 1 and 2 cannot be changed)

Level	User No.	Functions
Installer	01	(default=4112) perform all security functions except can disarm only if used to arm; can enter program mode; can change System Master code; cannot assign other user codes NOTE: For security purposes, the factory default installer code should be changed.
System Master	02	(default 1234) only one system master code per system; can perform all security functions, add/delete users in either partition, change system master code, view event log, set system clock, program keypad macro, program scheduled events, activate output devices (triggers/relays)
Partition Master (default)	P1 = 03 P2 = 33	Same as Master, except add/delete users limited to assigned partition only, (these users can be assigned different authority levels, if desired; any user can be assigned the partition master authority level)
0-User	03-49	perform security functions (arm, disarm, etc.) only; cannot add/delete users, view event log, set system clock or program scheduled events
1-Arm Only	see "user"	arm system only
2-Guest	see "user"	can disarm the system only if it was used to arm the system
3-Duress	see "user"	performs security functions, but also silently sends a duress message to the central station; reports as duress code user number.
4-Partition Master	see "user"	See Partition Master paragraph above; used to assign other user numbers as partition masters

Refer to the user guide for procedures on adding/deleting security codes and changing user attributes.

The following is a brief description of how to add users and user codes.

Changing the System Master code...

Using Installer code: Installer code + [8] + 02 + new code

Using current System Master code: System Master code + [8] + 02 + new code + new code again

Adding a User: Master code + [8] + 2-digit user no. + user's code

Deleting a User: Master code + [8] + 2-digit user no. + [#] [0]

Assigning Attributes: Master code + [8] + 2-digit user no. + [#] [attribute no.] + value

Attributes:	Values
1 = Authority Level	0-4 (see Authority Level table above)
2 = Access Group	0-8 (0 = not assigned to a group)
3 = Active Partition(s) for this user;	1, 2, 3 (common) Enter partitions consecutively if more than one and press [#] to end the entries.
4 = RF Zone No.	Assigns user number to button type zone for arm/disarm (keyfob must be enrolled in system first ; see Wireless Key Templates section).

Deactivating a key fob: You can deactivate the arming/disarming functions for a key fob (ex. if lost or stolen) by deleting the associated key fob user. See "Delete a User" above. Other key fob functions such as panic or device activation (if programmed) remain active. To fully remove the programming for a key fob, delete the zone(s) associated with the keyfob functions.

IMPORTANT SECURITY NOTICE

Please inform the User about the security importance of their key fob, and what to do if it is lost. Explain that the key fob is similar to their keys or access card. If lost or stolen, another person can compromise their security system. They should immediately notify the Dealer/Installer of a lost or stolen key fob. The Dealer/Installer will then remove the key fob programming from the security system.

5 = Open/Close Paging 1 for yes, 0 for no

Keypad Functions

The following is a brief list of system commands. For detailed information concerning system functions, refer to the User's Manual. For Touch Screen style keypad users, refer to the separate Touch Screen keypad (AUI) User's Guide.

Voice Keypads

The 6150V/6160V Voice Keypads provide the following features:

- Message Center, which lets the user record and playback one message.
- Voice Status, which can announce system status by using the STATUS key.
- Voice Chime, which can alert users to the opening of doors/windows while the system is disarmed.

Refer to the User Guide for specific procedures for activating and using these features.

Keypad Commands

Function	Description
Silence Burglary Alarms	Pressing any key will silence the keypad sounder for 10 seconds. Disarming the system will silence both keypad and external sounders.
Silence Fire or Carbon Monoxide Alarms	Press the OFF [1] key to silence the keypad sounder and, for fire alarms, the external sounder. The detector sounding stops when the contaminated air is cleared from the detector; see the detector's instructions for further information.
Quick Arm	If enabled (field *21), you can press [#] in place of the system's security code, plus the desired arming key (Away, Stay, Instant, Maximum)
Single-Button arming	If programmed (*57 Function Key menu mode), lettered keys A-D can be used for arming, using options 3-AWAY, 4-STAY, 5-NIGHT-STAY, or 6-Step-Arming If used, no security code is required to arm the system.
Alarm Memory	When the system is disarmed, any zones that were in an alarm condition during the armed period will be displayed. To clear this display, simply repeat the disarm sequence (enter the security code and press the OFF key) again.
Arming Away	Enter code + AWAY [2] or simply press appropriate lettered key on the keypads (see "Single-Button Arming" above). If the "Auto-Stay Arm" feature is enabled (field *84) and the entry/exit door is not opened and closed within the programmed exit delay time, the system will automatically arm in STAY mode if armed from a wired keypad (non-RF device). If the door is opened and closed within the exit delay period, the system arms in AWAY mode.
Arming Stay	Enter code + STAY [3] or simply press appropriate key on the keypads (see "Single-Button Arming" above). See "Arming Away" above for Auto-Stay arming feature.
Arming Night-Stay	Enter code + STAY [3] + STAY [3] or simply press appropriate key on the keypads (see "Single-Button Arming" above).
Arming Instant	Enter code + INSTANT [7].
Arming Maximum	Enter code + MAXIMUM [4] or simply press appropriate lettered key on the keypads (see "Single-Button Arming" above).
Disarming	Enter code + OFF [1]. If entry delay or an alarm is active, you do not need to press OFF.
Bypassing Zones	Enter code + BYPASS [6] + zone number(s).
Forced (Quick) Bypass	To automatically bypass all faulted zones, use the "Quick Bypass" method. Enter code + BYPASS + [#], then wait for all open zones to be displayed. Arm when display indicates "ZONE BYPASSED" and "READY TO ARM".
Chime Mode	Enter code + CHIME [9]. To turn chime off, enter code + CHIME again.
Activate Output Devices	If relay outputs (via a 4204, or 4229), or Powerline Carrier devices are used, two keypad entries available to the user are included. If programmed, these entries can be used to manually activate or deactivate the device(s) for starting or stopping some action, such as turning lights on or off, etc. These keypad entries are: [Security Code] + # + 7 + [2-digit Device #] activates (starts) that device. [Security Code] + # + 8 + [2-digit Device #] deactivates (stops) that device.

SUMMARY OF ARMING MODES

Arming Mode	Features for Each Arming Mode			
	Exit Delay	Entry Delay	Perimeter Armed	Interior Armed
AWAY	Yes	Yes	Yes	Yes
STAY	Yes	Yes	Yes	No
NIGHT-STAY	Yes	Yes	Yes	only those zones listed in Night-Stay zone list
INSTANT	Yes	No	Yes	No
MAXIMUM	Yes	No	Yes	Yes

Panic Keys

There are three Panic keys (A, B, and C) that, if programmed, can be used to manually initiate alarms and send a report to the central station.

Each key can be programmed for 24-hour Silent, 24-hour Audible, Fire, or Personal Emergency responses. The programmed Panic response is activated when the appropriate key is pressed for at least 2 seconds.

The Panic keys are identified by the system as follows:

Keys	Displayed as Zone
[A] (*/1)	95
[B] (*/#)	99
[C] (3/#)	96

IMPORTANT: For a Silent panic function (if programmed) to be of practical value, you must program a report code for the zone and the system must be connected to a central station.

Setting the Real-Time Clock

NOTE: All partitions must be disarmed before date/time can be set.

Set the time and date by doing the following:

1. +[#] + [6] [3]
(Master Code)

Alpha Display:

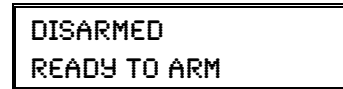

2. Press [*] when the time/date is displayed.
A cursor appears under the first digit of the hour.
To move cursor ahead, press []. To go back, press [#].*
 - Enter the 2-digit hour setting.
 - Enter the 2-digit minute setting.
 - Press [1] for PM or [2] for AM.
 - Enter the last two digits of the current year.
 - Enter the 2-digit month setting.
 - Enter the 2-digit day setting.
3. To exit, press [*] when cursor is at the last digit, or wait 30 seconds.

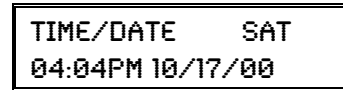

Various System Trouble Displays

Alpha Display	Fixed Disp.	Meaning
ALARM CANCELED	CA	will appear if an exit or interior zone contained a fault during closing at the time the Exit Delay ended (e.g., exit door left open), but the system was disarmed during the Entry Delay time. The alarm sounder and keypad sound continuously, but stop when the system is disarmed. No message will be transmitted to the central station.
EXIT ALARM	EA	appears when Exit Delay ends if an exit or interior zone contained a fault during closing. The alarm sounder and keypad sound continuously until the system is disarmed (or timeout occurs). An "Exit Alarm" message is sent to the central station. Also results if an alarm from an exit or interior zone occurs within 2 minutes after the end of an Exit Delay.
CHECK	CHECK	indicates that a problem exists with the displayed zone(s) and requires attention.
ALARM 1xx FAULT 1xx CHECK 1xx	1xx 1xx 1xx 91	indicates that communication between control and a zone expander or wireless receiver is interrupted, where "xx" is the device address. Check the wiring and DIP switch settings on the units. If field *199 is set to "1," all ECP module problems are displayed as "91." If there are wireless sensors in the system, the Check condition may also be caused by some change in the environment that prevents the receiver from receiving signals from a particular sensor.
SYSTEM LO BAT	BAT	with no zone number indicates that the system's standby battery is weak.
LO BAT	BAT	with a zone number and a once-per-minute beeping at the keypad indicates that a low-battery condition exists in the wireless sensor displayed (zone "00" indicates a wireless keypad). If the battery is not replaced within 30 days, a "CHECK" display may occur. NOTE: Some wireless sensors contain a non-replaceable long-life battery which requires replacement of the entire unit at the end of battery life (e.g., Nos. 5802, 5802CP).
TELCO FAULT	94	Telephone Line Failure, indicates that a monitored telephone line (if programmed in field *92) has been cut or disconnected. Depending on how the system was programmed, the keypad may also produce a trouble sound, and the external sounder may be activated. Silence by entering installer code + OFF.
Busy-Standby	dl	If this remains displayed for more than 1 minute, the system is disabled.
Modem Comm	CC	The system is in communication with the central station for change of function or status verification.
no display	no display	Power Failure If there is no keypad display at all and the LEDs are unlit, operating power (AC and battery) for the system has stopped and the system is inoperative. If the message "AC LOSS" (Alpha display keypads) or "NO AC" (Fixed-Word display keypads) is displayed, the keypad is operating on battery power only. If the battery standby capacity is used up during a prolonged AC power outage, the control's power will shut down to minimize deep discharge of the battery.
Comm. Failure	FC	A communication failure has occurred (event log 354; message not delivered)
Open Circuit	OC	The keypad is not receiving signals from the control; sees an open circuit.
Long Rng Trbl	bF	Backup communication device (LRR/GSM) had communication failure.
Bell Failure	70	Bell supervision failure.
RCVR Jam	90	RF jam detected.
KEYPAD LOW BAT	00 BAT	Wireless keypad low battery.
Phone Okay	Cd	The dialer test has been successful (CID code 601).
Dialer Off	d0	The dialer is disabled.
Test in Progress	dd	Walk test mode is active (CID code 607).
Upload Completed	dC	The upload or download session was completed.
Upload Failed	dF	The upload or download session failed before completion.

Testing the System

About Test Procedures

After the installation is complete, you should perform the following tests:

- System Test:** Checks that all zones have been installed properly and the system responds to faults.
Dialer Test: Checks that the phone connection to the central station is working properly.
Go/No Go Test: Checks that transmissions can be received from transmitters. Should be performed before permanently mounting transmitters.
RF Sniffer Mode: Checks that RF transmitter serial numbers have been properly enrolled.
Battery Tests: Automatic battery tests are performed by the system.

System Test

NOTE: Test mode can be entered from any keypad. However, faulted zones appear only on those keypads assigned to the partition to which the zone is assigned (i.e., partition 1 zones appear only on partition 1 keypads, etc.). To see another partition's faulted zones, view a keypad assigned to that partition or use the GOTO command (code +[*] + partition number 0-3, where 0 is the keypad's home partition).

With the system in the disarmed state, check that all zones are intact (not faulted). Doors and windows with contacts should be closed, PIRs should be covered (use a cloth to mask them temporarily if necessary). If a "NOT READY" message is displayed, press [*] to display the faulted zone(s). Restore faulted zone(s) if necessary, so that the "READY" message is displayed.

1. Enter Installer Code + 5 [TEST], then press "0" at the prompt to start Walk Test mode.

1=DIAL, 0=WALK

(no special display on Fixed-Word keypads)

The following will be displayed on the initiating keypad and a Contact ID report will be sent (code 607):

TEST IN PROGRESS

("dd" displayed on Fixed-Word Display Keypads)

2. Upon entering the system test mode, the outside sounder should sound for 1 second. If the backup battery is discharged or missing, the sounder may not turn on and a "LOW BATTERY" report will be transmitted with a "TEST" report. The keypad will beep about every 30 seconds as a reminder that the system is in the Test mode.
NOTE: Wireless motion detectors (Passive Infrared units) will send signals out only if they have been inactive for 3 minutes (conserves battery life).
3. Test all sensors using the procedure described in the User's Guide "Testing the System" section.
4. After checking sensors, turn off the test mode by entering installer code + OFF.

NOTE: Test mode automatically ends after 4 hours. During the final 5 minutes (after 3 hours 55 minutes of Test mode), the keypad emits a double-beep every 30 seconds to alert that the end of Test mode is nearing.

Checking Transmitter Enrollment (Sniffer Mode)

Use this mode to verify that all transmitters have been properly programmed. Make sure both partitions are disarmed before trying to enter this mode, since this is a system-wide command.

1. From a keypad in partition 1, press [Installer code] + [#] + 3.
(sniffer mode can be started only from partition 1)

NOTE: If the communicator is in the process of sending a report to the central station, the system will not go into the Sniffer mode. If so, wait a few minutes, and try again.

The keypads in both partitions will display all zone numbers of wireless units (in both partitions) programmed into the system. Fault each transmitter in turn, causing each one to send a signal. As the system receives a signal from each of the transmitters, the zone number of that transmitter disappears from the display.

2. After all transmitters have been checked, exit the sniffer mode by keying [Installer code] + OFF.
IMPORTANT: Sniffer mode does not automatically expire. You must manually exit Sniffer mode (by entering [Installer code] + OFF) to return to normal operation.

- NOTES:**
- All BR type units must physically be activated to clear the display.
 - When **one** button of a transmitter (RF, UR, or BR) is activated, all zones assigned to other buttons on that transmitter are cleared from the display. This also applies to 5816 and 5817 transmitters, which have multiple loops (zones).
 - Any transmitter that is not “enrolled” will not turn off its zone number.

Go/No Go Test Mode

The Go/No Go Test verifies adequate RF signal strength from the proposed transmitter location, and allow you to reorient or relocate transmitters if necessary, before mounting the transmitters permanently. This mode is similar to the Transmitter Test mode, except that the wireless receiver gain is reduced. This will enable you to make sure that the RF signal from each transmitter is received with sufficient signal amplitude when the system is in the normal operating mode.

1. Enter [Installer code] + [#] + 4 from the partition being tested. For multi-partition systems, repeat this test for each partition.
2. After you have placed transmitters in their desired locations and the approximate length of wire to be run to sensors is connected to the transmitter's screw terminals (if used), fault each transmitter. Do not conduct this test with your hand wrapped around the transmitter, as this will cause inaccurate results.
 - a. The keypad will beep three times to indicate signal reception and display the zone number.
 - b. If the keypad does not beep, you should reorient or move the transmitter to another location. Usually a few inches in either direction is all that is required.
3. If each transmitter produces the proper keypad response when it is faulted, you can then permanently mount each of the transmitters according to the instructions provided with them.
4. Exit the Go/No Go Test mode by entering: [any user code (partition-specific)] + OFF.

Dialer Communication Test and Periodic Test Reports

1. Enter Installer Code + 5 [TEST], then press “1” at the prompt to start the Dialer Test (checks phone line integrity only; does not confirm report transmissions).

1=DIAL, 0=WALK

(no special display on Fixed-Word keypads)

The keypad beeps twice and displays the following if test is successful:

PHONE OKAY

(“Cd” displayed on Fixed-Word Display Keypads)

A Contact ID report will also be sent (code 601)

If the dialer test is unsuccessful, “COMM FAILURE” (or FC) is displayed.

2. Enter Installer code + OFF to clear the display and exit.

Automatic Periodic Test Report

The system can be set to automatically send test reports (enabled in field *64; Contact ID code 602) at specified intervals. Frequency of the reports is set in Scheduling mode (event 11) or by the following key

- commands:
- installer code + [#] + 0 + 0** = test report sent every 24 hours
 - installer code + [#] + 0 + 1** = test report sent once per week
 - installer code + [#] + 0 + 2** = test report sent every 28 days

Each mode sets schedule 32 to the selected repeat option; the first test report is sent 12 hours after command.

To ensure that test reports are sent at the times expected, set the Real-Time Clock to the proper time **before** entering the test report schedule command.

Automatic Standby Battery Tests

1. An automatic test is conducted every 3 minutes to ensure that a standby battery is present and properly connected. If a battery is not present or is not properly connected, a “LOW BATTERY” message is displayed and, if so programmed, will be reported to the central station.
2. A battery capacity test is automatically conducted for 2 minutes every 4 hours, beginning 4 hours after exiting the Programming mode or after powering up the system. In addition, entry into the Test mode will also cause a battery capacity test to be initiated. If the battery cannot sustain a load, a “Low Battery” message is displayed and, if so programmed, will be reported to the central station.

Specifications & Accessories

Security Control

1. **Physical:** 12-1/2" W x 14-1/2" H x 3" D (318mm x 368mm x 76mm)
2. **Electrical:**
 VOLTAGE INPUT: 16.5VAC from plug-in 40VA transformer, ADEMCO 1361 (in U.S.A.)
 RECHARGEABLE BACKUP BATTERY: 12VDC, 4AH (sealed lead acid type). Charging Voltage: 13.8VDC.
 ALARM SOUNDER: 12V, 2.0 Amp output can drive 12V BELLS or can drive one or two 702 (series connected) self-contained 20-watt sirens. Do **not** connect two 702s in parallel.
 AUXILIARY POWER OUTPUT: 12VDC, 600mA max.
NOTE: For UL installations, Alarm Sounder plus Auxiliary Power currents should not exceed 600mA total.

 FUSE: Battery (4A) No. 300-01802
3. **Communication:**
 FORMAT SUPPORTED:
 ADEMCO Express: 10 characters/sec, DTMF (TouchTone) Data Tones, 1400/2300Hz ACK, 1400Hz KISSOFF.
 ADEMCO Low Speed: 10 pulses/sec, 1900Hz Data Tone, 1400Hz ACK/KISSOFF.
 Radionics/SESCOA:; 20 pulses/sec, 1800Hz Data Tone, 2300Hz ACK/KISSOFF.
 Can report 0-9, B-F
 Ademco Contact ID 10 characters/sec., DTMF (TouchTone) Data Tones, 1400/2300Hz ACK, 1400Hz KISSOFF.
 LINE SEIZE: Double Pole
 RINGER EQUIVALENCE: 0.1B
 FCC REGISTRATION No.: 5GBUSA-44003-AL-E
4. **Maximum Zone Resistance:** Zones 1–8 = 300 ohms excluding EOLR standard zones

Compatible Devices

- Keypads:** 6150 Fixed-Word Keypad, 6160 Alpha Keypad, 6150V and 6160V Voice Keypads, 6270 Touch Screen Keypad, Symphony Advanced User Interface
- Wireless Receivers:** 5881L/5882L: accepts up to 8 transmitters
 5881M/5882M: accepts up to 16 transmitters
 5881H/5882H: accepts up to system maximum transmitters
 5800TM Transmitter Module (used with Wireless 2-Way Keypads)
 5883 Transceiver: accepts up to system maximum transmitters
 6150RF Keypad/Transceiver: accepts up to system max. transmitters
- Zone Expansion:** 4219 WIRED EXPANSION MODULE
 4229 WIRED EXPANSION/RELAY MODULE
- Relay Module:** 4204 RELAY MODULE
- Phone Modules:** 4286 PHONE MODULE
- Communication Device (LRR):** VISTA-GSM4G

2-Wire Smoke Detector:

Detector Type	Model No.
Photoelectric w/heat sensor	2WT-B (System Sensor)
Photoelectric	2W-B (System Sensor)
Photoelectric	2151 w/B110LP base (System Sensor)
Photoelectric	FW-2S (Napco)

Transformers: 1361: 16.5VAC, 40VA Plug-In Transformer (No. 1361CN in Canada)
1361X10: 16.5VAC, 40VA Powerline Carrier device Interface AC Transformer

Sounders: AB12M 10" Motorized Bell & Box
1011BE12M 10" Motorized Bell & Box
702 Outdoor Siren
719 2-Channel Siren
713 High Power Speaker
746 Indoor Speaker
747 Indoor Siren
747PD Two-Tone Piezo Dynamic Indoor Siren
747UL Indoor Siren
748 Dual Tone Siren
749 Speaker/Horn
744 Siren Driver
745X3 Voice Siren Driver
705-820, 5-inch Round Speaker
713 Speaker
WAVE Speaker
WAVE2 Two-Tone Siren
WAVE2PD Two-Tone Piezo Dynamic Siren
5800WAVE Wireless Siren
System Sensor PA400B (beige)/; PA400R (red) Indoor Piezo Sounder

5800 Series Transmitter Input Loop Identification

All of the transmitters illustrated below have one or more unique factory assigned input (loop) ID codes. Each of the input loops requires its own programming zone (e.g., a 5804's four inputs require four programming zones).

<p>5800CO ENROLL AS "RF"</p>	<p>5800Micra ENROLL AS "RF"</p>	<p>5800SS1 ENROLL AS "RF"</p>	<p>5800WAVE SET HOUSE ID ENROLL AS "RF"</p>	<p>5801 ENROLL AS "UR OR" "RF"</p>	<p>5802 MN ENROLL AS "UR" OR "RF"</p>
<p>5802 MN2 ENROLL AS "UR" OR "RF"</p>	<p>5804/5804E ENROLL AS "BR"</p>	<p>5804BD/5804BDV ENROLL AS "BR" SET HOUSE ID</p>	<p>5805-6 ENROLL AS "BR"</p>	<p>5806/5806W3 5808/5808LST/5808W3 ENROLL AS "RF"</p>	<p>5809 ENROLL AS "RF"</p>
<p>5814 ENROLL AS "RF"</p>	<p>5815 ENROLL AS "RF"</p>	<p>5816 ENROLL AS "RF"</p>	<p>5816MN ENROLL AS "RF"</p>	<p>5817 ENROLL AS "RF"</p>	<p>5818MNL ENROLL AS "RF"</p>
<p>5819 ENROLL AS "RF"</p>	<p>5819S (WHS & BRS) ENROLL AS "RF"</p>	<p>5820/5820L ENROLL AS "RF"</p>	<p>5821 ENROLL AS "RF"</p>	<p>5828/5828V SET HOUSE ID</p>	<p>5853 ENROLL AS "RF"</p>
<p>5878 ENROLL AS "BR"</p>	<p>5890/5890PI ENROLL AS "RF"</p>	<p>5894PI ENROLL AS "RF"</p>	<p>5897-35 ENROLL AS "RF"</p>		

5800-003-V0

NOTE: For information on any transmitter not shown, refer to the instructions accompanying that transmitter for details regarding loop numbers, etc.

UL NOTE: The following transmitters are not intended for use in UL installations:

5802MN, 5802MN2, 5804, 5804BD, 5814, 5816TEMP, 5819, 5819WHS & BRS, and 5850.

Regulatory Agency Statements

FEDERAL COMMUNICATIONS COMMISSION (FCC) PART 15 STATEMENTS

The user shall not make any changes or modifications to the equipment unless authorized by the Installation Instructions or User's Manual. Unauthorized changes or modifications could void the user's authority to operate the equipment.

CLASS B DIGITAL DEVICE STATEMENT

This equipment has been tested to FCC requirements and has been found acceptable for use. The FCC requires the following statement for your information:

This equipment generates and uses radio frequency energy and if not installed and used properly, that is, in strict accordance with the manufacturer's instructions, may cause interference to radio and television reception. It has been type tested and found to comply with the limits for a Class B computing device in accordance with the specifications in Part 15 of FCC Rules, which are designed to provide reasonable protection against such interference in a residential installation. However, there is no guarantee that interference will not occur in a particular installation. If this equipment does cause interference to radio or television reception, which can be determined by turning the equipment off and on, the user is encouraged to try to correct the interference by one or more of the following measures:

- If using an indoor antenna, have a quality outdoor antenna installed.
- Reorient the receiving antenna until interference is reduced or eliminated.
- Move the radio or television receiver away from the receiver/control.
- Move the antenna leads away from any wire runs to the receiver/control.
- Plug the receiver/control into a different outlet so that it and the radio or television receiver are on different branch circuits.
- Consult the dealer or an experienced radio/TV technician for help.

This Class B digital apparatus complies with Canadian ICES-003.
Cet appareil numérique de la classe B est conforme à la norme NMB-003 du Canada.

INDUSTRY CANADA (IC) STATEMENTS

This device complies with FCC Part 15 and RSS210 of Industry Canada. Operation is subject to the following two conditions: (1) This device may not cause harmful interference, and (2) This device must accept any interference received, including interference that may cause undesired operation.

Cet appareil est conforme à la partie 15 des règles de la FCC & de RSS 210 des Industries Canada. Son fonctionnement est soumis aux conditions suivantes: (1) Cet appareil ne doit pas causer d'interférences nuisibles. (2) Cet appareil doit accepter toute interférence reçue y compris les interférences causant une réception indésirable.

TELEPHONE/MODEM INTERFACE

FCC Part 68

This equipment complies with Part 68 of the FCC rules. On the front cover of this equipment is a label that contains the FCC registration number and Ringer Equivalence Number (REN). You must provide this information to the telephone company when requested.

This equipment uses the following USOC jack: RJ31X

This equipment may not be used on telephone-company-provided coin service. Connection to party lines is subject to state tariffs. This equipment is hearing-aid compatible.

Industry Canada

NOTICE: The Industry Canada Label identifies certified equipment. This certification means that the equipment meets telecommunications network protective, operational and safety requirements as prescribed in the appropriate Terminal Equipment Technical Requirements document(s). The Department does not guarantee the equipment will operate to the user's satisfaction.

Before installing this equipment, users should ensure that it is permissible to be connected to the facilities of the local telecommunications company. The equipment must also be installed using an acceptable method of connection. The customer should be aware that compliance with the above conditions may not prevent degradation of service in some situations.

Repairs to certified equipment should be coordinated by a representative designated by the supplier. Any repairs or alterations made by the user to this equipment, or equipment malfunctions, may give the telecommunications company to request the user to disconnect the equipment.

Users should ensure for their own protection that the electrical ground connections of the power utility, telephone lines and internal metallic water pipe system, if present, are connected together. This precaution may be particularly important in rural areas.

Caution: Users should not attempt to make such connections themselves but should contact appropriate electric inspection authority, or electrician, as appropriate.

Ringer Equivalence Number Notice:

The **Ringer Equivalence Number** (REN) assigned to each terminal device provides an indication of the maximum number of terminals allowed to be connected to a telephone interface. The termination on an interface may consist of any combination of devices subject only to the requirement that the sum of the Ringer Equivalence Numbers of all the devices does not exceed 5.

Industrie Canada

AVIS: L'étiquette d'Industrie Canada identifie le matériel homologué. Cette étiquette certifie que le matériel est conforme aux normes de protection, d'exploitation et de sécurité des réseaux de télécommunications, comme le prescrivent les documents concernant les exigences techniques relatives au matériel terminal. Le Ministère n'assure toutefois pas que le matériel fonctionnera à la satisfaction de l'utilisateur.

Avant d'installer ce matériel, l'utilisateur doit s'assurer qu'il est permis de le raccorder aux installations de l'entreprise locale de télécommunication. Le matériel doit également être installé en suivant une méthode acceptée de raccordement. L'abonné ne doit pas oublier qu'il est possible que la conformité aux conditions énoncées ci-dessus n'empêche pas la dégradation du service dans certaines situations.

Les réparations de matériel homologué doivent être coordonnées par un représentant désigné par le fournisseur. L'entreprise de télécommunications peut demander à l'utilisateur de débrancher un appareil à la suite de réparations ou de modifications effectuées par l'utilisateur ou à cause de mauvais fonctionnement.

Pour sa propre protection, l'utilisateur doit s'assurer que tous les fils de mise à la terre de la source d'énergie électrique, de lignes téléphoniques et des canalisations d'eau métalliques, s'il y en a, sont raccordés ensemble. Cette précaution est particulièrement importante dans les régions rurales.

Avertissement : L'utilisateur ne doit pas tenter de faire ces raccordements lui-même; il doit avoir recours à un service d'inspection des installations électriques, ou à un électricien, selon le cas.

AVIS : L'indice d'équivalence de la sonnerie (IES) assigné à chaque dispositif terminal indique le nombre maximal de terminaux qui peuvent être raccordés à une interface. La terminaison d'une interface téléphonique peut consister en une combinaison de quelques dispositifs, à la seule condition que la somme d'indices d'équivalence de la sonnerie de tous les dispositifs n'excède pas 5.



RF EXPOSURE WARNING

The VISTA-GSM4G module must be installed to provide a separation distance of at least 7.8 in. (20 cm) from all persons and must not be co-located or operating in conjunction with any other antenna or transmitter except in accordance with FCC multi-transmitter product procedures.

UL NOTICES

1. Entry Delay No. 1 and No. 2 (fields *35, *36) cannot be greater than 30 seconds for UL Residential Burglar Alarm installations, and entry delay plus dial delay should not exceed 1 minute. For UL Commercial Burglar Alarm installations, total entry delay may not exceed 45 seconds.
2. For UL Commercial Burglar Alarm and UL Residential Burglar Alarm installations with line security, total exit delay time must not exceed 60 seconds. For UL Burglar Alarm installations without line security, total exit delay time must not exceed 120 seconds.
3. The maximum number of reports per armed period (field *93) must be set to "0" (unlimited) for UL installations.
4. Periodic testing (see scheduling mode) must be at least every 24 hours.
5. Alarm Sounder plus Auxiliary Power currents must not exceed 600mA total for UL installations (Aux power 500mA max.).
6. All partitions must be owned and managed by the same person(s).
7. All partitions must be part of one building at one street address.
8. If used, the audible alarm device(s) must be placed where it/they can be heard by all partitions.
9. For UL commercial burglar alarm installations the control unit must be protected from unauthorized access. The tamper switch installed to protect the control unit enclosure door is suitable for this purpose.
10. Remote downloading without an alarm company technician on-site (unattended downloading) is not permissible for UL installations.
11. Auto-disarming is not a UL Listed feature.
12. As SIA limits for delay of alarm reporting and sounding can exceed UL limits for commercial and residential applications, the following UL requirements per UL681 are provided:
The maximum time that a control unit shall be programmed to delay the transmission of a signal to a remote monitoring location, or to delay the energizing of a local alarm sounding device to permit the alarm system user to enter and disarm the system, or to arm the system and exit shall not exceed:
 - a) 60 seconds for a system with standard line security or encrypted line security,
 - b) 120 seconds for a system without standard line security or encrypted line security, or
 - c) 120 seconds for a system that does not transmit an alarm signal to a remote monitoring location.
13. This control is not intended for bank safe and vault applications.

SIA Quick Reference Guide

1. *31 Single Alarm Sounding per Zone: If "0" selected, "alarm sounding per zone" will be the same as the "number of reports in armed period" set in field *93 (1 if one report, 2 if 2 reports, unlimited for zones in zone list 7).
2. *34 Exit Delay: Minimum exit delay is 45 seconds.
3. *35/*36 Entry Delay 1 and 2: Minimum entry delay is 30 seconds.
4. *37 Audible Exit Warning: Feature always enabled; field does not exist.
5. *39 Power Up in Previous State: Must be "1," power up in previous state.
6. *40 PABX Access Code or Call Waiting Disable: If call waiting is used, call waiting disable option in field *91 must be set.
7. *50 Burglary Dial Delay: Delay must be minimum of 30 seconds.
8. *59 Exit Error Alarm Report Code: Always enabled.
9. *68 Cancel Report Code: Default is "code enabled."
10. *69 Recent Closing Report Code: Always enabled.
11. *91 Option Selection: Exit Delay option should be enabled. If call waiting is used, Call Waiting Disable must be set to "1" (enabled).
12. *93 No. reports in Armed Period: Must be set for 1 or 2 report pairs.
13. Cross zone timer programming is set in field *85; cross zone pairs are assigned in zone list 4 using *81 Zone List mode.
14. Duress code is assigned by using the "add a user code" procedure found in the User Guide. Enable Duress code reporting by programming zone 92 using *56 Zone Programming mode.
15. Fire alarm verification is a built-in system feature when a zone is programmed for zone type 16.

Notes

Notes

Limitations and Warranty

WARNING

THE LIMITATIONS OF THIS ALARM SYSTEM

While this System is an advanced design security system, it does not offer guaranteed protection against burglary, fire or other emergency. Any alarm system, whether commercial or residential, is subject to compromise or failure to warn for a variety of reasons. For example:

- Intruders may gain access through unprotected openings or have the technical sophistication to bypass an alarm sensor or disconnect an alarm warning device.
- Intrusion detectors (e.g., passive infrared detectors), smoke detectors, and many other sensing devices will not work without power. Battery-operated devices will not work without batteries, with dead batteries, or if the batteries are not put in properly. Devices powered solely by AC will not work if their AC power supply is cut off for any reason, however briefly.
- Signals sent by wireless transmitters may be blocked or reflected by metal before they reach the alarm receiver. Even if the signal path has been recently checked during a weekly test, blockage can occur if a metal object is moved into the path.
- A user may not be able to reach a panic or emergency button quickly enough.
- While smoke detectors have played a key role in reducing residential fire deaths in the United States, they may not activate or provide early warning for a variety of reasons in as many as 35% of all fires, according to data published by the Federal Emergency Management Agency. Some of the reasons smoke detectors used in conjunction with this System may not work are as follows. Smoke detectors may have been improperly installed and positioned. Smoke detectors may not sense fires that start where smoke cannot reach the detectors, such as in chimneys, in walls, or roofs, or on the other side of closed doors. Smoke detectors also may not sense a fire on another level of a residence or building. A second floor detector, for example, may not sense a first floor or basement fire. Finally, smoke detectors have sensing limitations. No smoke detector can sense every kind of fire every time. In general, detectors may not always warn about fires caused by carelessness and safety hazards like smoking in bed, violent explosions, escaping gas, improper storage of flammable materials, overloaded electrical circuits, children playing with matches, or arson. Depending on the nature of the fire and/or location of the smoke detectors, the detector, even if it operates as anticipated, may not provide sufficient warning to allow all occupants to escape in time to prevent injury or death.
- Passive Infrared Motion Detectors can only detect intrusion within the designed ranges as diagrammed in their installation manual. Passive Infrared Detectors do not provide volumetric area protection. They do create multiple beams of protection, and intrusion can only be detected in unobstructed areas covered by those beams. They cannot detect motion or intrusion that takes place behind walls, ceilings, floors, closed doors, glass partitions, glass doors, or windows. Mechanical tampering, masking, painting or spraying of any material on the mirrors, windows or any part of the optical system can reduce their detection ability. Passive Infrared Detectors sense changes in temperature; however, as the ambient temperature of the protected area approaches the temperature range of 90° to 105°F (32° to 40°C), the detection performance can decrease.
- Alarm warning devices such as sirens, bells or horns may not alert people or wake up sleepers if they are located on the other side of closed or partly open doors. If warning devices are located on a different level of the residence from the bedrooms, then they are less likely to waken or alert people inside the bedrooms. Even persons who are awake may not hear the warning if the alarm is muffled by noise from a stereo, radio, air conditioner or other appliance, or by passing traffic. Finally, alarm warning devices, however loud, may not warn hearing-impaired people.
- Telephone lines needed to transmit alarm signals from a premises to a central monitoring station may be out of service or temporarily out of service. Telephone lines are also subject to compromise by sophisticated intruders.
- Even if the system responds to the emergency as intended, however, occupants may have insufficient time to protect themselves from the emergency situation. In the case of a monitored alarm system, authorities may not respond appropriately.
- This equipment, like other electrical devices, is subject to component failure. Even though this equipment is designed to last as long as 10 years, the electronic components could fail at any time.

(Continued)

WARNING
THE LIMITATIONS OF THIS ALARM SYSTEM
(Continued)

The most common cause of an alarm system not functioning when an intrusion or fire occurs is inadequate maintenance. This alarm system should be tested weekly to make sure all sensors and transmitters are working properly. The security keypad (and remote keypad) should be tested as well.

Wireless transmitters (used in some systems) are designed to provide long battery life under normal operating conditions. Longevity of batteries may be as much as 4 to 7 years, depending on the environment, usage, and the specific wireless device being used. External factors such as humidity, high or low temperatures, as well as large swings in temperature, may all reduce the actual battery life in a given installation. This wireless system, however, can identify a true low-battery situation, thus allowing time to arrange a change of battery to maintain protection for that given point within the system.

Installing an alarm system may make the owner eligible for a lower insurance rate, but an alarm system is not a substitute for insurance. Homeowners, property owners and renters should continue to act prudently in protecting themselves and continue to insure their lives and property.

We continue to develop new and improved protection devices. Users of alarm systems owe it to themselves and their loved ones to learn about these developments.

CONTACTING TECHNICAL SUPPORT

PLEASE, before you call Technical Support, be sure you:

- READ THE INSTRUCTIONS!
- Check all wiring connections.
- Determine that the power supply and/or backup battery are supplying proper voltages.
- Verify your programming information where applicable.
- Note the proper model number of this product, and the version level (if known) along with any documentation that came with the product.
- Note your Honeywell customer number and/or company name.

Having this information handy will make it easier for us to serve you quickly and effectively.

<i>Technical Support:</i> 1-800-645-7492 (8 a.m.-10 p.m. E.S.T.)
<i>MyWebTech:</i> http://www.honeywell.com/security/hsc/resources/MyWebTech

– INDEX –

1321 AC Transformer.....	1-2, 2-3, 2-11	Defining Output Functions	5-10	PABX Access Code.....	4-2
1361X10.....	2-3, 2-11, 2-12, 8-2	Descriptor Programming.....	5-15	Pager #1 Phone No.....	4-7, 4-8
24-Hour Audible Alarm	3-21	Device address. 2-5, 2-11, 3-19, 4-12, 5-8, 6-7		Pager Programming.....	4-7
24-Hour Auxiliary Alarm.....	3-21	Device number	5-26	Pager Programming Fields	4-7
24-Hour Silent Alarm	3-21	Dialer Communication Test.....	7-2	Pager Report Options	4-8
3+1 and 4+1 Standard Formats.....	6-1	DIP Switches	2-9	Paging.....	4-6
3-Digit Number	5-15, 5-16	Disarm.....	3-21	Panic Keys	6-6
4204.. 1-2, 2-2, 2-6, 2-11, 3-19, 5-8, 5-9, 5-10, 6-5, 8-1		Disarming	5-11, 6-5	Partitions	5-1
4219.....	1-1, 1-2, 2-2, 2-7, 2-8, 8-1	Double-Balanced	2-6	Perimeter Burglary.....	3-20
4229 1-1, 1-2, 2-2, 2-6, 2-7, 2-8, 2-11, 3-19, 5-8, 5-9, 5-10, 6-5, 8-1				Periodic Test Reports	7-2
4286.....	2-14, 5-16	Enrolling	2-9, 5-1	Phone Line	2-13
4286 Phone Module	5-15	Entering serial number.....	5-5	Phone Module . 1-1, 2-2, 2-5, 2-13, 2-14, 2-15, 4-1, 4-7, 5-15, 5-16, 17, 8-1	
5800 Series Transmitters.....	2-9	Entry Delay.....	3-21, 4-9, 6-6, 6-7	Phone Module Access Code.....	4-1
5800TM.....	2-9, 8-1	Entry Delay 02.....	4-2	Power Failure	5-11, 6-7
5801	2-9	Entry/Exit Burglary.....	3-20	power supply	2-2, 2-4, 10-1
5802.....	2-9, 6-7	Entry/Exit Burglary.....		Power Up In Previous State.....	4-2
5802CP	2-9, 6-7	Entry/Exit Burglary.....		Powerline Carrier Device (X-10) House ID	4-1
5827	2-9, 4-1	EOLR	2-6, 8-1	Powerline Carrier Devices 1-2, 2-11, 6-5	
5827BD	2-9, 4-1	Event Logging	4-6	Primary Phone No.	4-3
5881	2-2, 2-8	Exit Delay	4-2, 4-6, 4-9, 6-6, 6-7	Primary Phone No.	4-2
9-pin connector.....	2-10	Exit Error Alarm	3	prompt to confirm.....	5-5
		Exit Error Alarm	6-7	PSC04 Powerline Interface.....	2-11
AC Power Supply	1-2	Exit Error Report Code	4-4		
AC Transformer.....	2-3, 2-12, 8-2	Expansion Zones.....	2-7	Quick Arm Enable.....	4-11
Ademco Contact ID	6-3	Expert Programming Mode . 5-1, 5-4, 5-7			
Alarm Bell Timeout	4-2			Registering the Control	2-15
Alarm Output	2-2, 2-4	Factory Defaults	3-20	Relay Modules.....	1-2, 2-11
Alarm Sounder Timeout.....	4-2	Fast Busy Signal.....	2-13	Relay Programming	3-19
Alpha Descriptor.....	5-1, 5-4, 5-15	Fault Delay Time	4-6	Report Code . 4-4, 4-5, 4-6, 4-9, 5-2, 5-5, 6-1	
Alpha Vocabulary	5-15	Fire Sounder Timeout.....	4-2	Report Code Formats	6-1
Alpha Vocabulary	5-15	Forced Bypass Function.....	4-1	Reports In Armed Period	4-7
Alpha Vocabulary List.....	5-15	Function Key Programming	5-14	Response time.....	2-7, 4-6, 5-2
ALPHA VOCABULARY LIST	5-17	Function Keys.....	4-7, 5-14	RF House ID Code	2-8, 4-1
Arm Away/Stay Report Code.....	4-4			RF Interference.....	2-8
Arm-Away.....	3-21	Go/No Go Test Mode.....	7-2	RF jam detection	1-1, 4-1
Arming Away	6-5			RF Jam Option	2-8
Arming Instant	6-5	Handshake	6-1	RF Receiver	2-1, 2-2, 2-5, 2-8, 3
Arming Modes	6-6	Hardwired zones.....	1-1, 5-3	RF System.....	4-1
Arming Stay.....	6-5	HAYES Modem	1-1	Ring Detection Count For Downloading	4-7
Arm-Stay	3-21	House ID	2-9, 4-1	RJ31X Jack	2-13
Audio Alarm Verification	2-13, 4-6			SA4120XM-1 Cable	2-3
Audio Alarm Verification (AAV).....	2-13	Ideal Model 61-035	2-3	Schedules.....	5-26
AUI.....	2-5	Input Device Type.....	5-5	Security Codes	1-1, 6-4
Authority Levels.....	6-4	Installer Code	3-20, 4-7, 7-1, 7-2	Silent Burglary	3-22, 5-2, 5-11, 3
Auxiliary Output	2-2	Interior Follower.....	3-20, 5-2, 5-11	Silent Panic	6-6
		Interior w/Delay.....	3-21, 5-2, 5-11	Single Alarm Sounding Per Zone.....	4-1
Backup Battery	1-2			Sniffer Mode	5-4, 7-1
Battery Life	2-9	Keypad addresses.....	2-5, 4-11	Sounder connections	2-4
Battery Tests	7-1, 7-2	Keypad Programming Fields.....	4-11	Supervised Fire	3-21
Bell Supervision.....	2-4	Keyswitch	2-10, 3-22, 5-2, 3	Supplementary Power	2-4
Bell Supervision Jumper.....	2-4	Kissoff	5-11, 6-1	Swinger Suppression.....	4-7
Bypassing Zones	6-5			System Communication.....	4-9, 5-2, 6-1
		Lock	2-1	System Operation....	5-6, 5-7, 5-11, 5-26
CA.....	4-5	Long Range Radio.....	4-3, 3, 8-1	System Status Report Codes.....	4-4
Cabinet.....	2-1	Low Battery Message	7-2	System Test	7-1
CALIFORNIA STATE FIRE MARSHALL	2-2				
Caller ID Unit.....	2-13	Model 112.....	2-10		
CANCELED ALARM.....	4-5	Modem	6-7		
Character (ASCII) Chart	17	Module Addresses.....	5-9		
Character List	5-16	Momentary switch.....	2-10		
Charging Voltage.....	8-1				
Chime By Zone.....	4-1	No Alarm Response	3-22, 5-11		
Chime Mode	4-10, 6-5			On-Board triggers	2-14
Clean Me Option.....	2-7			Output Device Mapping	3-19, 5-8, 5-9
Common zone	5-1			Output Devices.....	5-8
Communication	5-14, 6-1, 8-1			Output Functions	5-8
Configurable Zone Type Programming	4-9			Output relays.....	1-2
Fields	4-9				
Confirmation Of Arming Ding.....	4-2				
Contact ID Reporting	8-1				
CSFM.....	2-2				
Custom Message.....	5-16				
Custom Words.....	5-15, 5-16, 17, 5-19, 5-20				

Tamper switch	2-10, 9-2	UL	2-2, 2-4, 2-11, 8-1	Zone Doubling	2-6
Telco Line	2-13, 3	Verify Operation.....	2-7	Zone Lists.....	3-19, 5-12, 5-13
Telephone Line Monitoring	1-1	Vocabulary List.....	5-15	Zone Not Used	3-20
Temporal pulse sounding	3-21	Wire Run Chart.....	2-4, 2-5	Zone Programming Procedure.....	5-1
Test Mode	7-1, 7-2	Wireless Key Predefined Default Templates	5-7	Zone Type	5-5
Test Restore Report Code	4-5	Wireless Key Programming Templates	5-6	Zone Types	3-20, 5-2, 5-11
Touch Screen Device (AUI) Enable	4-11	Wireless key templates.....	5-6		
Touchpads	4-4	Word String	5-16		
Transmitter Input Types.....	5-3	Worksheet	2-2		
Trigger outputs	2-12				
Trouble by Day/	3-21				
Trouble Displays.....	6-6, 6-7, 6-8				

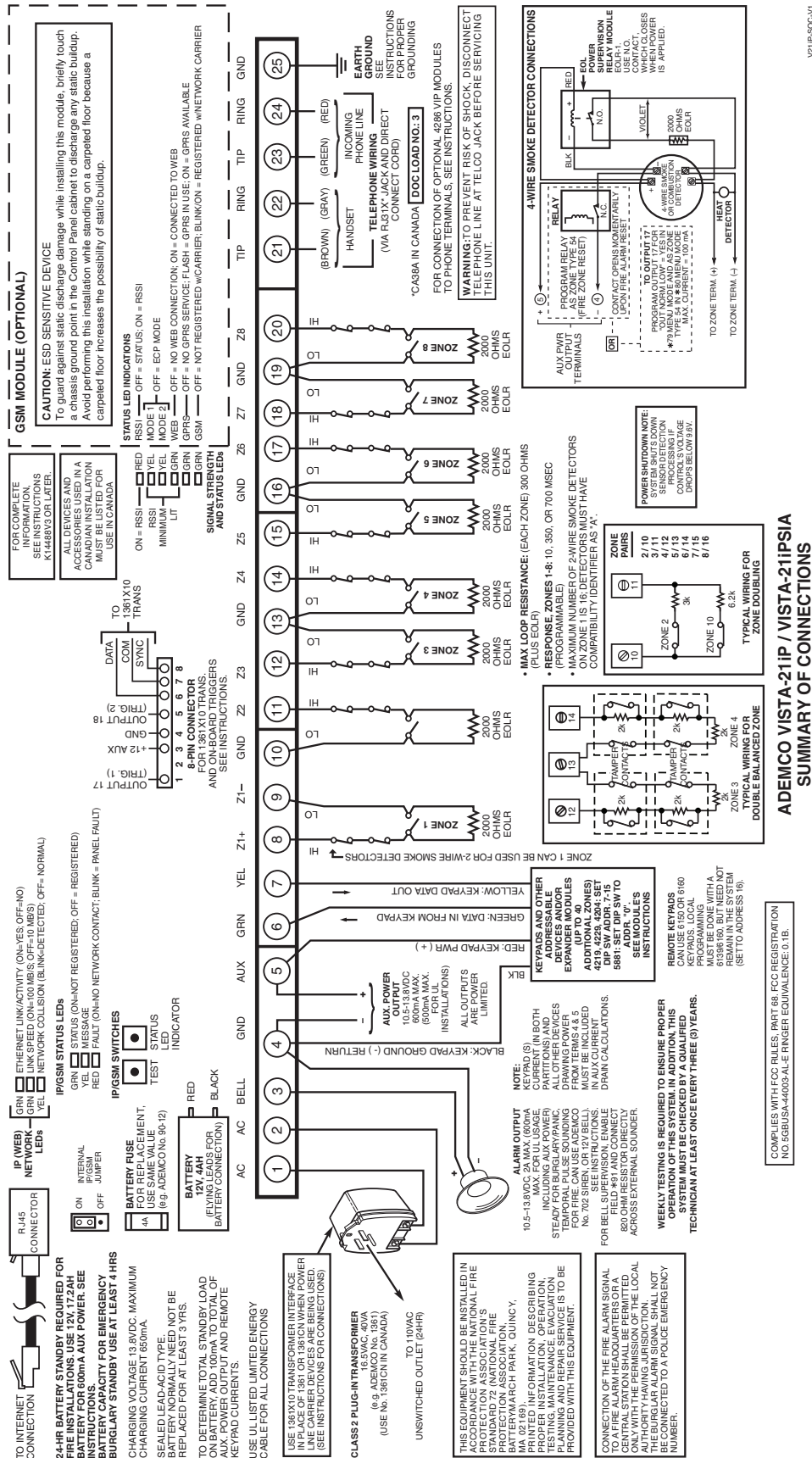

Figure 17. Summary of Connections

WARRANTY INFORMATION

For the latest warranty information, please go to:

www.honeywell.com/security/hsc/resources/wa

Honeywell

2 Corporate Center Drive, Suite 100
P.O. Box 9040, Melville, NY 11747
Copyright © 2008 Honeywell International Inc.
www.honeywell.com/security



K14488V3 10/12 Rev. C