

ADEMCO 4204 Relay Module – Installation Instructions

GENERAL INFORMATION

The ADEMCO 4204 Relay Module provides from one to four dry, form-C (SPDT) relay outputs to compatible control/communicators. It connects to the control's keypad wiring terminals.

The 4204 can be mounted inside the control's cabinet or mounted remotely depending on the application. Refer to the UL notes below for certain restrictions.

If mounted remotely, the 4204 has a built-in tamper switch that allows it to detect and report the removal of its cover to the control. Second, communication to the 4204 is supervised so that it cannot be disconnected from the keypad wiring without detection by the control. If the wiring is cut, a tamper or alarm signal will result, to indicate that this device (and possibly other devices connected to the keypad wiring) has become inoperative.

INSTALLATION

For UL Installations:

When used with controls that do not support cover tamper or supervise communications wiring to the 4204, mount the 4204 inside the control's cabinet.

When used with controls that support cover tamper and supervise communications wiring to the 4204, mount the 4204 may either be mounted inside the control's cabinet or mounted remotely.

UL

- For dry, indoor use only. Do not install in air-handling spaces.
- For UL Commercial Burglary installations, the 4204 must be tamper protected or mounted in a tamper-protected cabinet.
- In Commercial Fire applications, the module cannot be mounted in the control unit's cabinet, but must be mounted in an external UL864-listed cabinet.

When mounted inside the control's cabinet, some controls allow the 4204 to be mounted horizontally as follows: insert the self-tapping screws (provided) in two adjacent raised tabs on the back of the cabinet. Leave the heads projecting 1/8". Hang the 4204 on the screw heads via two of the slotted holes on the back of its housing. The 4204's cover need not, in this case, be tamper-protected. Set DIP switch 1 to "ON" if the cover is not used (see table). See the control's instructions for additional information.

When the 4204 is mounted remotely, it can be mounted horizontally or vertically and the built-in tamper switch can be used. Wires can exit from the side or via the breakout on the back of its housing. The DIP switch

must be set with its position 1 "OFF" and when the installation is completed, the unit's tamper-protected cover must be replaced.

NOTE: For EN50131-3 compliance a tie-wrap must be secured around the case of a remotely mounted 4204. Apply tie-wrap around the case to the right of the large zone wire opening (4-inch case width). This is in opposition of the tamper switch and magnet.

NOTE: CE installations require maximum cable length of 30 meters.

Affix the connections label that accompanies the 4204 to the inside of the 4204's cover (if the cover is used) or to the inside of the control's cover.

CONNECTIONS AND SETTINGS

Select and set an address for the 4204, using its DIP switch as shown in the DIP switch table. Each 4204 must be assigned a unique address so the control can identify and communicate with the 4204. The address to set is determined by the particular control to be used. See the control's installation instructions. As shipped, the DIP switch is set for address "0".

UL

- For UL fire installations, no more than one wire per terminal may be connected.
- Use only 14-22AWG wire.

NOTE: All power-limited wiring must be separated from non-power limited wiring by 1/4".

Make connections to the 4204's four relays via 12-position terminal block TB2. Refer to the control's installation instructions for specific information on how to program the activation options for the relays.

Make connections to the control's keypad wiring points via 4-position terminal block TB1, the 4-pin plug, or both (wire color connections are the same). See the diagram on the other side of this page.

SPECIFICATIONS

Physical: 6-7/16" W x 4-1/4" H x 1-1/4" D
(163mm x 108mm x 32mm)

Electrical:

Input Voltage: 12VDC nominal (10-14VDC, from control's remote keypad connection points)

Input Current: 15mA standby + 40mA per active relay

Contact Rating: 2A max. at 28VDC/AC (resistive loads)

WARRANTY

For the latest warranty information, please go to:
<http://www.honeywell.com/security/hsc/resources/wa>

DIP SWITCH SETTINGS

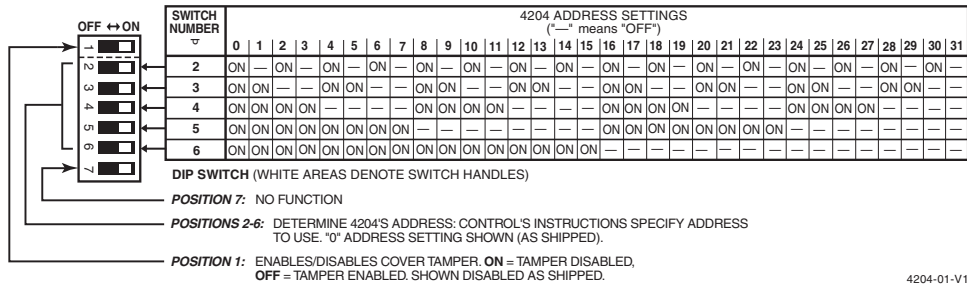

4204-01-V1

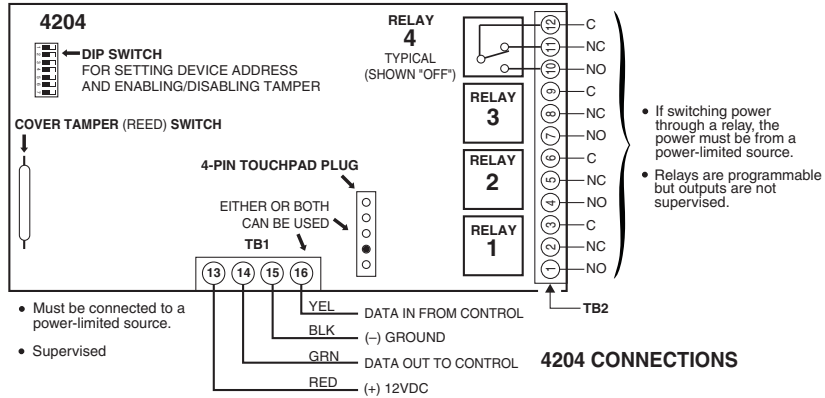

4204-02-V2

REFER TO THE INSTALLATION INSTRUCTIONS FOR THE CONTROL WITH WHICH THIS DEVICE IS USED FOR DETAILS REGARDING THE LIMITATIONS OF THE ENTIRE ALARM SYSTEM.

FEDERAL COMMUNICATIONS COMMISSION STATEMENTS

The user shall not make any changes or modifications to the equipment unless authorized by the Installation Instructions or User's Manual. Unauthorized changes or modifications could void the user's authority to operate the equipment.

CLASS B DIGITAL DEVICE STATEMENT

This equipment has been tested to FCC requirements and has been found acceptable for use. The FCC requires the following statement for your information:

This equipment generates and uses radio frequency energy and if not installed and used properly, that is, in strict accordance with the manufacturer's instructions, may cause interference to radio and television reception. It has been type tested and found to comply with the limits for a Class B computing device in accordance with the specifications in Part 15 of FCC Rules, which are designed to provide reasonable protection against such interference in a residential installation. However, there is no guarantee that interference will not occur in a particular installation. If this equipment does cause interference to radio or television reception, which can be determined by turning the equipment off and on, the user is encouraged to try to correct the interference by one or more of the following measures:

- If using an indoor antenna, have a quality outdoor antenna installed.
- Reorient the receiving antenna until interference is reduced or eliminated.
- Move the radio or television receiver away from the receiver/control.
- Move the antenna leads away from any wire runs to the receiver/control.
- Plug the receiver/control into a different outlet so that it and the radio or television receiver are on different branch circuits.
- Consult the dealer or an experienced radio/TV technician for help.

INDUSTRY CANADA CLASS B STATEMENT

This Class B digital apparatus complies with Canadian ICES-003.
Cet appareil numérique de la classe B est conforme à la norme NMB-003 du Canada.

FCC / IC STATEMENT

This device complies with Part 15 of the FCC Rules, and RSS210 of Industry Canada. Operation is subject to the following two conditions: (1) This device may not cause harmful interference, and (2) This device must accept any interference received, including interference that may cause undesired operation.

Cet appareil est conforme à la partie 15 des règles de la FCC & de RSS 210 des Industries Canada. Son fonctionnement est soumis aux conditions suivantes: (1) Cet appareil ne doit pas causer d'interférences nuisibles. (2) Cet appareil doit accepter toute interférence reçue y compris les interférences causant une réception indésirable.

Honeywell

2 Corporate Center Drive, Suite 100
P.O. Box 9040, Melville, NY 11747
Copyright © 2008 Honeywell International Inc.
www.honeywell.com/security



N8909V4 10/12 Rev. B